



# Gas Equipment

PRODUCT  
CATALOG  
2014 | 2015



# Miller® now offers oxy-fuel equipment.

As the leader in welding and cutting technology, Miller has always made it a top priority to provide the very best solutions to the industry — no matter how challenging the application. With that very principle in mind, we are expanding our metal cutting technology offering to include oxy-fuel equipment.

**This expansion is a result of transitioning the Smith Equipment® brand to Miller.**



Smith Equipment has long been known for its premium torches and tips, and you will continue to

receive the same high quality oxy-fuel equipment you've come to know and trust from the brand. The only difference — the name on the product will change to another trusted brand in welding and cutting: Miller.

The first step in fully transitioning the Smith Equipment product lines to the Miller brand can be found in the oxy-fuel equipment in this catalog.

Miller and Smith Equipment have a mutual commitment to manufacturing the most reliable



equipment in the industry, as well as providing the best technical and customer service support.

Based on these common goals, you can be assured that you'll now find the best products to meet your oxy-fuel equipment needs, whether you're a professional or a do-it-yourselfer.

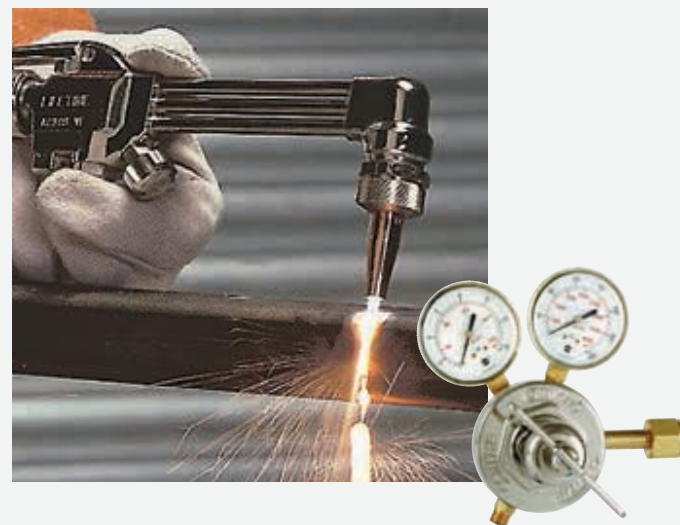

## Outfits

**Outfits include just about everything you need to get started on your cutting, welding, brazing or heating projects. Our heavy-duty, medium-duty and Versa-Torch™ torches are covered by our True Blue® lifetime torch warranty — the best in the industry, and the only warranty that covers normal wear and tear. The Toughcut™ and Tag-A-Long™ torches are backed by a 3-year limited warranty.**



### Heavy-Duty Outfits (pages 4-5)

Our premium heavy-duty outfits are capable of performing almost any cutting, welding, brazing or heating operation with the widest array of general and special-purpose tip options available. The rugged high-flow torch is capable of cutting up to 8-inch-thick steel and accommodates large heating tips, while the one-piece hand-cutting torches will cut up to 12 inches. These robust torches and regulators provide maximum durability even in the harshest environments.



### Medium-Duty Outfits (page 6)

Our medium-duty outfits are capable of a wide range of cutting, welding, brazing or heating applications, and provide excellent agility for precision cutting operations of up to 6 inches. These outfits feature quality construction throughout, and the torch and regulators are built to provide years of reliable service.



### Toughcut™ Outfits (page 7)

Toughcut medium-duty outfits are value priced and capable of cutting, welding, brazing or heating. The torch design provides excellent agility for precision cutting operations of up to 6 inches. This series includes many of the features of more expensive outfits, while remaining an economical, yet highly flexible option.



### Tag-A-Long™ and Versa-Torch™ Outfits (page 8)

These complete, portable oxy-acetylene outfits weigh less than 35 pounds, and are housed in polyethylene carriers designed for mobility and ease of storage. Outfits are capable of performing many welding, brazing or soldering operations, as well as precision cutting. The Versa-Torch with a broad selection of attachments available, is ideal for many specialty applications.



MillerWelds.com     
1-800-4-A-Miller (1-800-426-4553)

# Heavy-Duty Cutting, Welding & Heating



**HBA-40510**

**Cuts up to 8 inches (203 mm)** with optional tips  
**Welds up to 1/2 inch (13 mm)** with optional tips

These premium heavy-duty outfits feature our proven in-tip gas mixing technology and *include torch-mount flashback arrestors*. This combination greatly improves operator safety and increases torch life. The outfits feature rugged, highly accurate brass regulators. Outfits with Series 40™ regulators feature 2.5-inch (Series 30™, 2-inch) corrosion-resistant gauges and shatter-resistant polycarbonate lenses. Outfits are complete with safety and operations manual.

*Note: Welding may require additional equipment depending on which outfit is ordered. See chart below.*



Torches are covered by our lifetime warranty when used with authentic Miller | Smith tips. Regulators are covered by a three-year limited warranty.



**HBA-40510 / HBA-40300**  
with heavy-duty regulators



**HBA-30510 / HBA-30300**  
with medium-duty regulators



**HBA-30510LP / HBA-30510MP**  
with medium-duty regulators

*Note: All outfits packaged in outfit box shown above. Cutting capacity with tips supplied in acetylene outfits is up to 1-1/4 inches (32 mm).*

Stock Number	Fuel Gas	Torch Handle	Cutting Attachment	Cutting Tip	Welding Tip	Heating Tip	Oxygen Regulator	Fuel Gas Regulator	Includes
<b>HBA-40510</b>	Acetylene	WH200A	SC209	SC12-1 SC12-2	SW205	ST602	40-175-540 CGA 540	40-15-510 CGA 510	25-ft. (7.6 m) 1/4-in. (6 mm) twin hose, lighter, safety glasses, tip cleaner, H743 torch-mount flashback arrestors, operations manual  Propane/Propylene (LP/MP) outfits include 20-ft. (6.1 m) 1/4-in. (6 mm) "T" grade hose and check valves, not flashback arrestors
<b>HBA-40300</b>								40-15-300 CGA 300	
<b>HBA-30510</b>	Acetylene	WH200A	SC209	SC12-1	SW205	ST602	30-100-540 CGA 540		
<b>HBA-30300</b>							30-15-300 CGA 300		
<b>HBA-30510LP</b>	Propane or Natural Gas	WH200A	SC209	SC40-1	—	ST615	30-100-540 CGA 540	30-50-510 CGA 510	
<b>HBA-30510MP</b>	Propylene	WH200A	SC209	SC60-1	—	ST815	30-100-540 CGA 540	30-50-510 CGA 510	

# Heavy-Duty Cutting



**HBS-H510S**  
**HBS-H300S**

**Cuts up to 12 inches (305 mm)** with optional tips

Hand cutting torch outfits are built for the toughest jobs. They feature a SC229 nickel-plated cutting torch with a reversible cutting lever and an ease-on oxygen design for smooth starts and restarts. These outfits come with heavy-duty Series 40™ regulators which feature 2.5-inch polished brass gauges for corrosion resistance, shatter-resistant polycarbonate lenses, and stainless steel diaphragms for extended service life in the toughest applications. The HB190 Hard Hat™ gauge/regulator guards are made from rugged steel. Outfits are complete with safety and operations manual.



Torches are covered by our lifetime warranty when used with authentic Miller | Smith tips. Regulators are covered by a three-year limited warranty.



**HBAS-30510**  
**HBAS-30300**

**Cuts up to 12 inches (305 mm)** with optional tips

Hand cutting torch outfits are built for the toughest jobs. They feature a SC229 nickel-plated cutting torch with a reversible cutting lever and an ease-on oxygen design for smooth starts and restarts. These outfits come with medium-duty Series 30™ regulators which feature 2-inch corrosion-resistant gauges and shatter-resistant polycarbonate lenses. Outfits are complete with safety and operations manual.



*Note: Cutting capacity with tips supplied in HBS outfit is up to 1-1/4 inches (32 mm). Cutting capacity with tips supplied in HBAS outfit is up to 5/8 inch (16 mm).*

Stock Number	Fuel Gas	Cutting Torch	Cutting Tip	Oxygen Regulator	Fuel Gas Regulator	Includes
<b>HBS-H510S</b>	Acetylene	SC229	SC12-2	40-175-540S CGA 540	40-15-510S CGA 510	HB190 Hard Hat gauge/regulator guard, operations manual  20-ft. (6.1 m) 3/16-in. (5 mm) twin hose, lighter, safety glasses, tip cleaner, H743 torch-mount flashback arrestors, operations manual
<b>HBS-H300S</b>					40-15-300S CGA 300	
<b>HBAS-30510</b>	Acetylene	SC229	SC12-1	30-100-540 CGA 540	30-15-510 CGA 510	
<b>HBAS-30300</b>					30-15-300 CGA 300	

## Medium-Duty Cutting, Welding & Heating



**MBA-30300**

**Cuts up to 6 inches (153 mm)** with optional tips  
**Welds up to 3/8 inch (9.8 mm)** with optional tips

These premium medium-duty outfits feature quality construction throughout and are built to provide reliability and extended service. Outfits feature our proven in-tip gas mixing technology and *include torch-mount flashback arrestors*. This combination greatly improves operator safety and increases torch life. Outfits feature rugged, highly accurate Series 30™ regulators with 2-inch gauges constructed with Sure Seat™ technology and shatter-resistant polycarbonate lenses. Outfits are complete with safety and operations manual.

*Note: Welding may require additional equipment depending on which outfit is ordered. See chart below.*



Torches are covered by our lifetime warranty when used with authentic Miller | Smith tips. Regulators are covered by a three-year limited warranty.



**MBA-30510 / MBA-30300**



**MBA-30510LP / MBA-30510MP**

*Note: All outfits packaged in outfit box shown above. Cutting capacity with tips supplied in acetylene outfits is up to 5/8 inch (16 mm). Welding capacity is up to 1/8 inch (3 mm).*

Stock Number	Fuel Gas	Torch Handle	Cutting Attachment	Cutting Tip	Welding Tip	Heating Tip	Oxygen Regulator	Fuel Gas Regulator	Includes
<b>MBA-30510</b>	Acetylene	WH100	MC509	MC12-0	MW205	MT603	30-100-540 CGA 540	30-15-510 CGA 510	20-ft. (6.1 m) 3/16-in. (5 mm) twin hose, lighter, safety glasses, tip cleaner, H743 torch-mount flashback arrestors, operations manual
<b>MBA-30300</b>				MC12-1				30-15-300 CGA 300	
<b>MBA-30510LP</b>	Propane or Natural Gas	WH100	MC509	MC40-1	—	MT805	30-100-540 CGA 540	30-50-510 CGA 510	Propane/Propylene (LP/MP) outfits include 20-ft. (6.1 m) 1/4-in. (6 mm) "T" grade hose and check valves, not flashback arrestors
<b>MBA-30510MP</b>	Propylene	WH100	MC509	MC60-1	—	MT805	30-100-540 CGA 540	30-50-510 CGA 510	

## Toughcut™ Cutting, Welding & Heating



**MB55A-510**

**Cuts up to 6 inches (153 mm)** with optional tips  
**Welds up to 3/8 inch (9.8 mm)** with optional tips

Versatile Toughcut outfits include many features found on more expensive outfits. The Toughcut series is perfect for a multitude of applications such as farm, ranch, hobby, automotive, refrigeration, light fabrication, and repair. Outfits feature rugged, reliable Series 30™ medium-duty regulators, and are complete with safety and operations manual.

*Note: Welding and heating may require additional equipment depending on which outfit is ordered. See chart below.*



Torches and regulators are covered by a three-year limited warranty.



**MB55A-510 / MB55A-300**



**MB54A-510 / MB54A-300**



**MB54-510L / MB54-300L**

*Note: All outfits packaged in clam shell shown above. Cutting capacity with tips supplied in acetylene outfits is up to 5/8 inch (16 mm). Welding capacity is up to 1/8 inch (3 mm).*

Stock Number	Fuel Gas	Torch Handle	Cutting Attachment	Cutting Tip	Welding Tip	Heating Tip	Oxygen Regulator	Fuel Gas Regulator	Includes
<b>MB55A-510</b>	Acetylene	CW5A	CC509P	MC12-1	MW205	MT603	30-100-540 CGA 540	30-15-510 CGA 510	20-ft. (6.1 m) 3/16-in. (5 mm) twin hose, lighter, safety glasses, safety check valves, operations manual
<b>MB55A-300</b>								30-15-300 CGA 300	
<b>MB54A-510</b>	Acetylene	CW5A	CC509P	MC12-1	MW205	—	30-100-540 CGA 540	30-15-510 CGA 510	Safety glasses, safety check valves, operations manual
<b>MB54A-300</b>								30-15-300 CGA 300	
<b>MB54A-B9</b> British fitting	Acetylene	CW5A	CC509P	MC12-1	MW205	—	30-100-B9 G5/8A-14RH	30-15-B9 G5/8A-14LH	Safety glasses, safety check valves, operations manual
<b>MB54-510L</b>	Acetylene	CW5A	CC509P	MC12-1	MW205	—	30-100-540 CGA 540	30-15-510 CGA 510	
<b>MB54-300L</b>								30-15-300 CGA 300	
<b>MB54A-510LP</b>	Propane	CW5A	CC509P	MC40-1	—	—	30-100-540 CGA 540	30-50-510 CGA 510	20-ft. (6.1 m) 1/4-in. "T" grade hose, lighter, safety glasses, safety check valves, operations manual
<b>MB54A-510MP</b>	Propylene	CW5A	CC509P	MC60-1	—	—	30-100-540 CGA 540	30-50-510 CGA 510	

# Tag-A-Long™ and Versa-Torch™



TL-550

VT-4T



Versa-Torch torch is covered by our lifetime warranty when used with authentic Miller | Smith tips.

Tag-A-Long torch and all regulators are covered by a three-year limited warranty.

## TL-550/TL-500 Tag-A-Long Outfits (Acetylene)

Portable, lightweight Tag-A-Long cutting and welding outfits are ready to go where you need them. Compact design stores easily for road travel or when not in use. Series 30™ regulators provide efficient and dependable control of gases. The high-density polyethylene carrier is extremely durable and includes a hose wrap and covered storage compartment for accessories. Outfit also includes reverse flow check valves for added safety plus safety and operations manual.

## VT-4T Versa-Torch Outfit

This is one of the most versatile systems on the market. A broad selection of cutting, welding and specialty attachments (see below) makes the Versa-Torch ideal for manufacturing, maintenance and repair, air conditioning, refrigeration, plumbing, metal fabrication, jewelry, metal sculpture and many other applications. The Versa-Torch outfit features a lightweight nickel-plated torch handle and cutting attachment. The high-density polyethylene carrier is rugged and lightweight. Outfit also includes reverse flow check valves for added safety plus safety and operations manual.

Both the Tag-A-Long and Versa-Torch outfits use "MC" medium-duty cutting tips.

# Combination Torch and Tip Packages



16206 heavy-duty



16205 medium-duty

## Combination torch with cutting, welding and heating tips plus flashback arrestors

- Heavy-duty**  
Cuts up to 8 inches (203 mm) with optional tips  
Welds up to 1/2 inch (13 mm) with optional tips
- Medium-duty**  
Cuts up to 6 inches (153 mm) with optional tips  
Welds up to 3/8 inch (9.8 mm) with optional tips

These premium, versatile kits come with tips to do most jobs. They include either our classic SC or MC cutting assembly with a heating tip, welding tip, cutting tip and torch-mount flashback arrestors, plus safety and operations manual. Torches are capable of cutting up to 5/8 inch (16 mm) with tip included. Our thick-wall welding and heating tips hold up well to excess heat and are capable of providing years of service. The Graf-Tite® cutting tip seats hold up far longer and require less replacement than traditional metal-to-metal seats. Torches may be used with alternate fuel gases and tips designated for alternate fuel.



Torches are covered by our lifetime warranty when used with authentic Miller | Smith tips.

## Versa-Torch Brazing/Soldering Tip Selection

Tip Number	Brazing Capacity Copper Pipe Dia. Inches (mm)	Drill Size
AW201	1/4 – 3/8 (6 – 10)	71
AW203	3/8 – 5/8 (10 – 16)	67
AW205	1/2 – 7/8 (12 – 22)	57
AW207	5/8 – 1-3/8 (16 – 35)	54
AW209	3/4 – 2-1/8 (19 – 54)	49
AW210	7/8 – 2-5/8 (22 – 65)	44
LT103	1/2 – 3/4 (12 – 19)	63
LT104	5/8 – 1 (16 – 25)	56
LT106	3/4 – 1-1/2 (19 – 38)	52
NE153	5/8 – 1 (16 – 25)	44
NE154	7/8 – 1-5/8 (22 – 41)	36

Tip Number	Output BTU/Hour	Consumption (SCFH)	
		Oxygen	Fuel
AT605	41,230	32	29
13716	16,080	17	17
13715	16,600	38	12

See page 11 for standard for AW1A Versa-Torch torch handle.  
See page 38 for Kevlar brazing hose 14779-4-10.

## Combination torch with cutting tips plus flashback arrestors

- Heavy-duty**  
Cuts up to 8 inches (203 mm) with optional tips  
Welds up to 1/2 inch (13 mm) with optional tips
- Medium-duty**  
Cuts up to 6 inches (153 mm) with optional tips  
Welds up to 3/8 inch (9.8 mm) with optional tips

These premium kits come with either our classic SC or MC cutting assembly with two cutting tips and torch-mount flashback arrestors, plus safety and operations manual. Torches in the acetylene outfits are capable of cutting up to 5/8 inch (16 mm) with tips included. The Graf-Tite® cutting tip seats hold up far longer and require less replacement than traditional metal-to-metal seats. Torches may be used with alternate fuel gases and tips designated for alternate fuel.



16280 heavy-duty



16281 medium-duty

Cutting capacity with tips supplied in outfits is up to 3/8 inch (10 mm). Welding capacity is up to 1/8 inch (3 mm).

Stock Number	Fuel Gas	Torch Handle	Cutting Attachment	Cutting Tip	Welding/Brazing Tip	Oxygen Regulator	Fuel Gas Regulator	Includes
TL-500 (No Tanks)	Acetylene	CW5A	CC509P	MC12-0	MW203	30-100-540 CGA 540	30-15-200 CGA 200	12.5-ft. (3.8 m) 3/16-in. (5 mm) twin hose, carrier, lighter, safety glasses, regulator-mount safety check valves, operations manual, "R" 20-cu.-ft. oxygen and "MC" 10-cu.-ft. acetylene cylinders (cylinders not included with TL-500)
TL-550								
VT-4T	Acetylene	AW1A	AC309	MC12-00	LT103 LT104 LT106	30-100-540 CGA 540	30-15-200 CGA 200	12.5-ft. (3.8 m) 3/16-in. (5 mm) twin hose, carrier, lighter, safety glasses, regulator-mount safety check valves, operations manual, "R" 20-cu.-ft. oxygen and "MC" 10-cu.-ft. acetylene cylinders, AT60 tip tube, 13716 heating head

Stock Number	Fuel Gas	Torch Handle	Cutting Attachment	Cutting Tip	Welding Tip	Heating Tip	Includes
16206 (Heavy-duty)	Acetylene	WH200A	SC209	SC12-1	SW203	ST602 (40,000 Avg. BTU/Hr.)	H743 torch-mount flashback arrestors, operations manual
16205 (Medium-duty)	Acetylene	WH100	MC509	MC12-1	MW203	MT603 (40,000 Avg. BTU/Hr.)	
16280 (Heavy-duty)	Acetylene	WH200A	SC209	SC12-0, SC12-1	—	—	H743 torch-mount flashback arrestors, operations manual
16281 (Medium-duty)	Acetylene	WH100	MC509	MC12-0, MC12-1	—	—	
16280LP (Heavy-duty)	Propane	WH200A	SC209	SC40-0, SC40-1	—	—	
16281LP (Medium-duty)	Propane	WH100	MC509	MC40-0, MC40-1	—	—	

## Torch Handles

Our torch handles are 100-percent tested and inspected. They are available in three capacities to match any job requirement: heavy-duty, medium-duty and standard-duty.

Torches have silver-brazed joints to provide overall strength and rigidity for safe performance under rugged conditions. Torch handles are individually tested to maintain our reputation for quality and dependable performance.



Torch handles are covered by our lifetime warranty when used with authentic Miller | Smith tips. CW5A Toughcut™ handle has a 3-year limited warranty.

### Construction features

- 1. Internal threads**  
Threads are protected from damage if the torch is dropped, eliminating costly torch repair, replacement or downtime.
- 2. Double-tube handle**  
Tube-within-a-tube design provides strength while reducing weight. Internal tube is silver brazed for extra protection, strength and leak resistance.
- 3. Adjustable valve resistance**  
Special PTFE packing provides a gas-tight seal while allowing the “drag” to be adjusted to the individual preference.
- 4. Stainless steel ball-style valves**  
Corrosion-resistant balls and brass seating surfaces provide gall resistance and positive, chatter-free seating.
- 5. Replaceable hose connections (WH200A)**  
Connections are easily replaced if damaged on the heavy-duty WH200A handle.

### Fuel Gas Chart

Generic Name	Trade Name
Acetylene	—
Propane and Propane-Based Mixtures	Propane-butane, Flamex, Acetogen, Chem-O-Lene, Florida Industrial Gas, Hy-Temp, Fuel Gas, I.G. Gas, Chem-Gas, Lingas, Chemtone
Propylene	HPG, Apachi, B-Plus, Gulf HP Gas, HEF, Liquifuel, B.T.U.
Natural Gas (Methane)	Natural Gas, City Gas

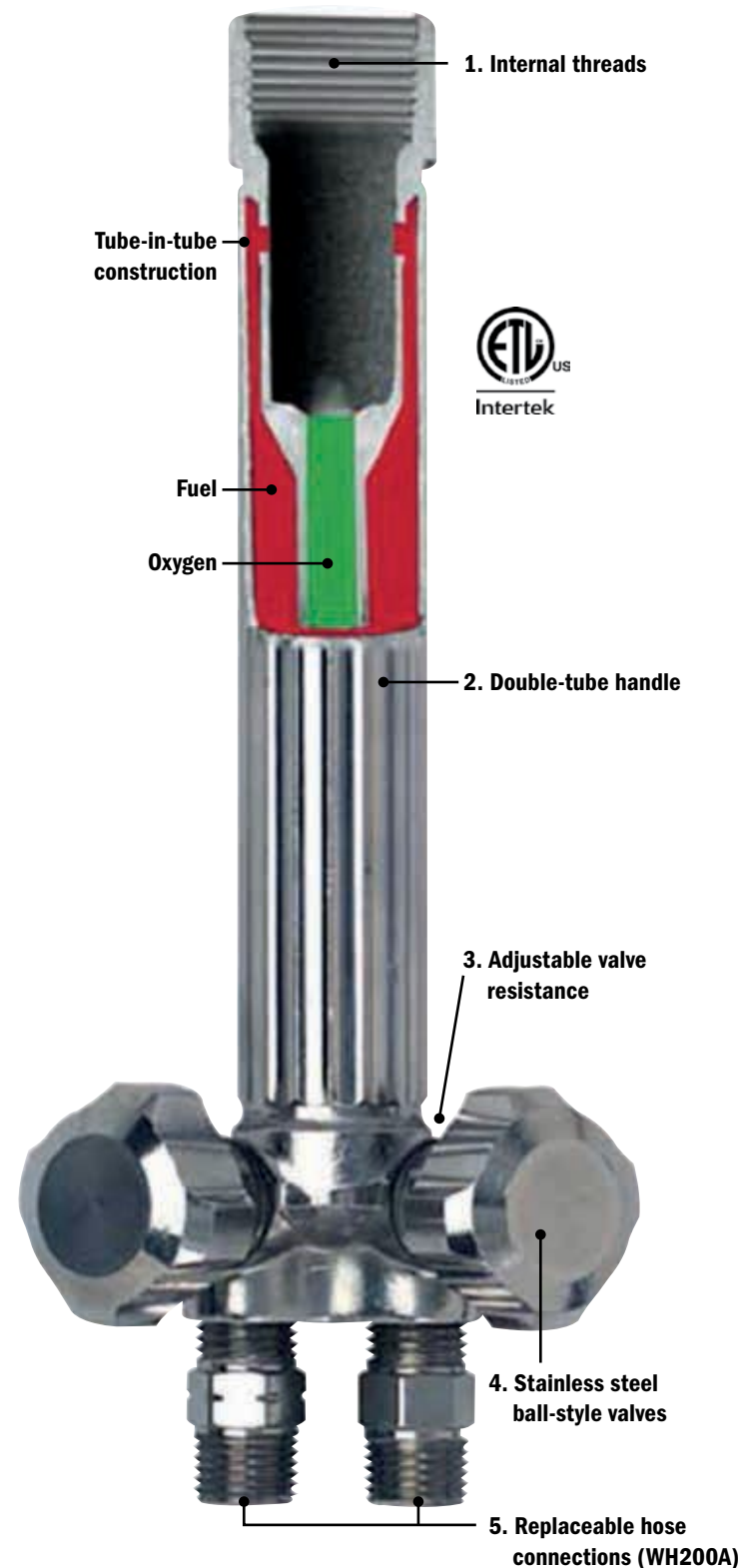

## Heavy-Duty Handle

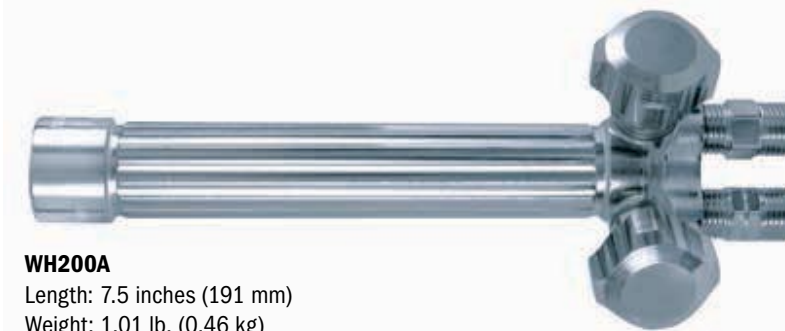

**WH200A**  
Length: 7.5 inches (191 mm)  
Weight: 1.01 lb. (0.46 kg)  
Handle diameter: 1 inch (25.4 mm)  
**Valve assembly replacement**  
G729-5A (also for SW1A, SW1B and WH200)

### WH200A

Heavy-duty handle allows high gas flow for large cutting tips and heating tips. Heavy-duty handles have replaceable hose connections. “B”-size inlet connections are 9/16”-18. WH200A torch handle is covered by our lifetime warranty when used with authentic Miller | Smith tips.

**Compatible cutting attachments**  
SC209, SC200, SC205, SC509, DG205, DG209 and DG200

**Compatible tips**  
Welding: SW200 and SW400 Series  
Heating: ST600 and ST800 Series

## Medium-Duty Handles

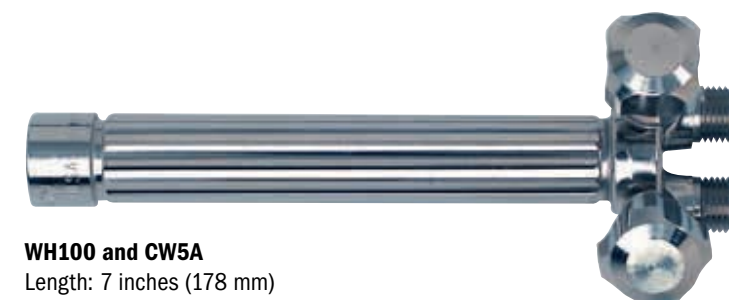

**WH100 and CW5A**  
Length: 7 inches (178 mm)  
Weight: 0.86 lb. (0.39 kg)  
Handle diameter: 15/16 inch (24 mm)  
**Valve assembly replacement**  
LW17 (also for MW5 and MW5A)

### WH100 CW5A (Toughcut™ handle)

Easy handling, high-quality mid-size torch handle. Handles all but the highest volume heating and heaviest welding needs. Features rugged silver-brazed construction, forged brass butt and precision machined brass head. Stainless steel ball-type valves reduce uneven valve wear and provide easy flame adjustment. “B”-size inlet connections are 9/16”-18 right and left hand. WH100 torch handle is covered by our lifetime warranty when used with authentic Miller | Smith tips.

*Note: CW5A Toughcut handle has a 3-year limited warranty and is not covered by our lifetime warranty.*

**Compatible cutting attachments**  
MC505, MC509 and DG109A

**Compatible tips**  
Welding: MW200 and MW400 Series  
Heating: MT600 and MT800 Series

## Standard-Duty Handle



**AW1A**  
Length: 5.75 inches (146 mm)  
Weight: 0.37 lb. (0.17 kg)  
Handle diameter: 11/16 inch (17 mm)  
**Valve assembly replacement**  
AW11A

### AW1A Airline™

Specially designed to handle standard-duty welding, brazing, cutting and fabricating. Light weight and compact size provide easy handling, even in confined areas. Needle valves located at front end for easy one-hand flame adjustment. “A”-size inlet connections are 3/8”-24 right and left hand. AW1A torch handle is covered by our lifetime warranty when used with authentic Miller | Smith tips.

**Compatible cutting attachment**  
AC309

**Compatible tips**  
Welding: AW200 and AW400 Series  
Heating: AT600 Series  
Twin Flame Tips: AT600 and AT600X6

## Cutting Attachments

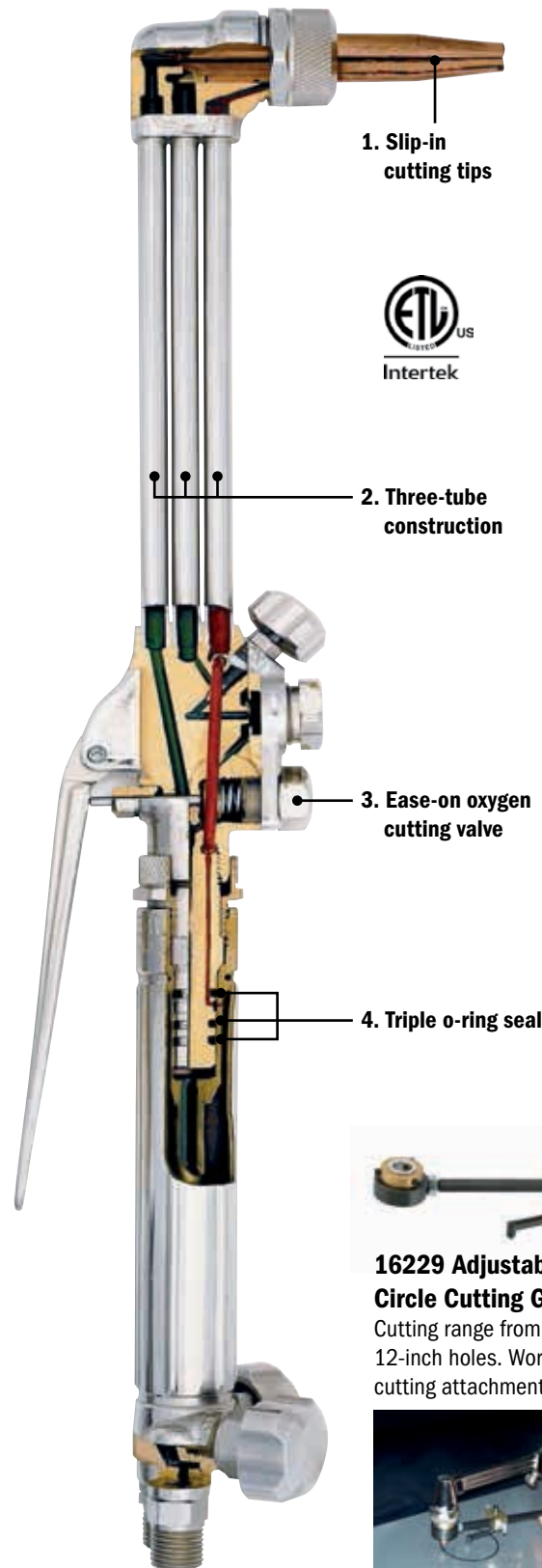

1. Slip-in cutting tips



2. Three-tube construction

3. Ease-on oxygen cutting valve

4. Triple o-ring seal



### 16229 Adjustable Circle Cutting Guide

Cutting range from 5/8 to 12-inch holes. Works with all cutting attachments.



Our premium-quality cutting attachments are 100-percent tested and inspected. They are available in three capacities to match any job requirement: heavy-duty, medium-duty and standard-duty.

Cutting attachments have silver-brazed joints to provide overall strength and rigidity for safe performance under rugged conditions. Attachments are individually tested to maintain our reputation for quality and dependable performance.



Cutting attachments are covered by our lifetime warranty when used with authentic Miller | Smith tips. CC509P Toughcut™ attachment has a 3-year limited warranty.

### Construction features

- 1 **Slip-in cutting tips**  
Save time when changing tips – no wrench needed. Resilient Graf-Tite® seat material protects tip from nicking and maintains positive seating. Requires less replacement than metal-to-metal seat designs.
- 2 **Three-tube construction**  
Gases are kept separated, eliminating mixing tube burnout. Our thick-wall, high-capacity stainless steel tubes provide high gas flow and superior strength.
- 3 **Ease-on oxygen cutting valve**  
Allows smooth piercing and keyhole free starts and restarts.
- 4 **Triple o-ring seal**  
Provides positive gas seating, and allows rotation during operation eliminating hose resistance during cutting.

### Cutting Tip Compatibility

Attachment Number	Tip Compatibility
SC205 and SC209	Acetylene: SC12-00 thru SC12-5, SC56-1 thru SC56-5
	Propane and Propane-Based: SC40-0 thru SC40-4, SC46-2 thru SC46-5, SC50-00 thru SC50-5
	Propylene: SC60-0 thru SC60-5, SC36-1 thru SC36-4
	SC Series Special-Purpose Tips (except SC112 and SC83)
MC505, MC509, and CC509P*	Acetylene: MC12-00 thru MC12-5 (AC309: thru MC12-4)
	Propane and Propane-Based: MC40-00 thru MC40-4
	Propylene: MC60-0 thru MC60-4
AC309	MC Series Special-Purpose Tips

\*Supplied in Toughcut™ outfits – 3-year warranty.

## Heavy-Duty Attachments



**SC205 and SC209**  
Length: 12.5 inches (318 mm)  
Weight: 1.83 lb. (0.83 kg)  
Head angle: 75 degrees (SC205), 90 degrees (SC209)

**Repair kit**  
SC101 (also for DG200 Series)

## Medium-Duty Attachments

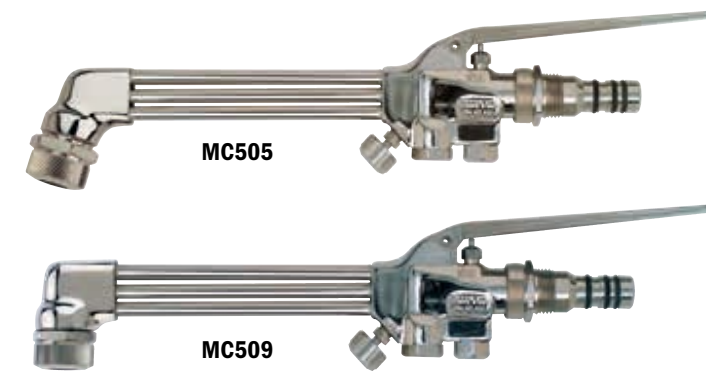

**MC505, MC509 and CC509P**  
Length: 11.25 inches (286 mm)  
Weight: 1.1 lb. (0.5 kg)  
Head angle: 75 degrees (MC505), 90 degrees (MC509)

**Repair kit**  
MC101 (also for DG100 Series)

## Standard-Duty Attachment

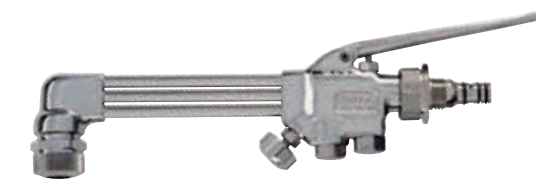

**AC309**  
Length: 8.5 inches (216 mm)  
Weight: 1 lb. (0.44 kg)  
Head angle: 90 degrees

### SC200 Series

Cuts up to 8-inch (203 mm) thick steel. Solid silver-brazed construction. Features o-ring seating and easy-to-change slip-in Graf-Tite® cutting tips with cost-saving soft seats. Use with any industrial fuel gases – acetylene, propane, natural gas, propylene, hydrogen, and many others. Several models of standard and special-purpose tips are available for use in SC200 Series cutting attachments. SC200 series torch handles are covered by our lifetime warranty when used with authentic Miller | Smith tips.

**Compatible handles**  
WH200A, WH200, SW1B, SW1A and SW1

**Compatible cutting tips**  
See SC Series tips on pages 28-30

### MC500 Series CC509P (Toughcut™ attachment)

Popular medium-duty cutting attachment easily cuts up to 6-inch (153 mm) steel. Solidly constructed to last a lifetime – silver-brazed joints, stainless steel tubes, brass forged butt and head. This torch has the same quality features and construction as the larger and heavier Miller | Smith cutting attachments. Use with any industrial fuel gases – acetylene, propane, butane, natural gas, propylene, hydrogen and many others. MC500 series torch handles are covered by our lifetime warranty when used with authentic Miller | Smith tips.

*Note: CC509P Toughcut attachment has a 3-year limited warranty and is not covered by our lifetime warranty.*

**Compatible handles**  
WH100, CW5A, MW5A and MW5

**Compatible cutting tips**  
See MC Series tips on page 31

### AC309 Airline™

Small, lightweight cutting attachment with cutting capacity up to 3-inch thick (76 mm) steel. This torch has the same quality construction and features built into each Miller | Smith cutting attachment. AC309 torch handle is covered by our lifetime warranty when used with authentic Miller | Smith tips.

**Compatible handles**  
AW1A and AW10A

**Compatible cutting tips**  
See MC Series tips on page 31

# Hand Cutting Torches

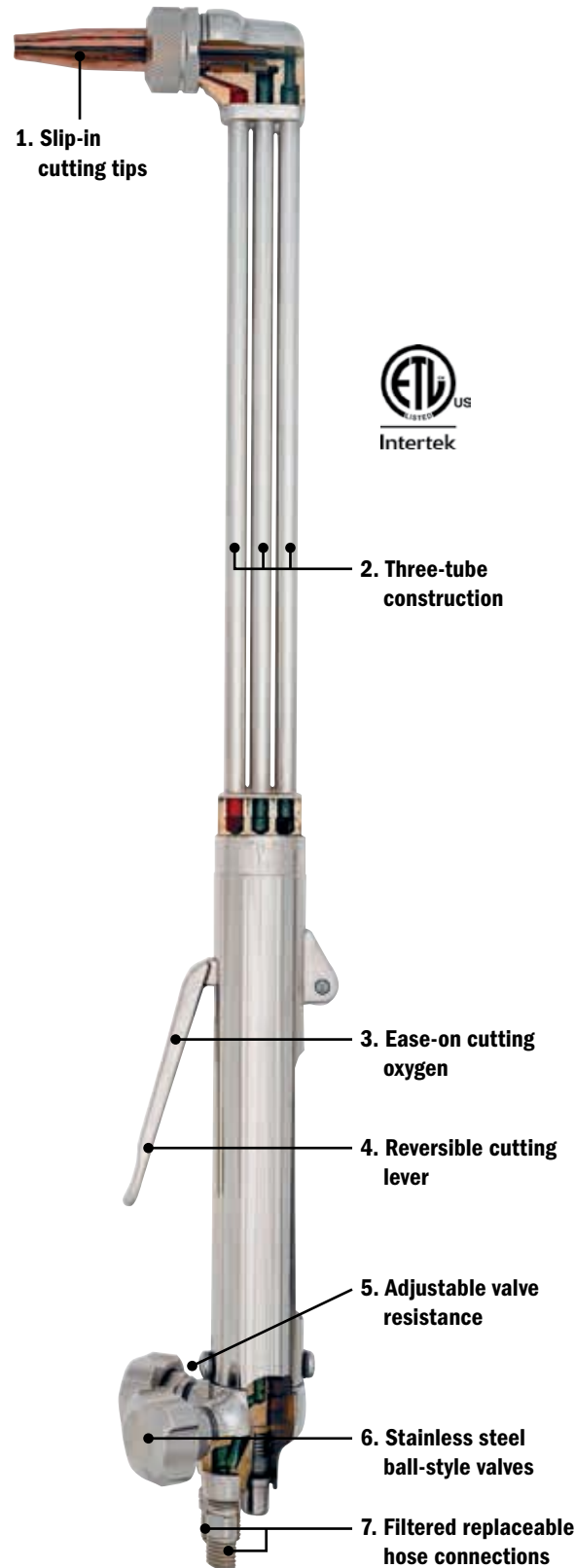

**Our hand cutting torches are heavy-duty capacity, and 100-percent tested and inspected.**

Cutting torches feature solid construction and ease of operation for hundreds of jobs in construction, fabricating, shipyards, salvage and other related industries. Torches have silver-brazed joints throughout, heads and butts are machined from dense forgings, and stainless steel ball-style control valves provide positive gas shut-off. Torches are individually tested to maintain our reputation for quality and dependable performance.



Cutting torches are covered by our lifetime warranty when used with authentic Miller | Smith tips.

## Construction features

- 1 Slip-in cutting tips**  
Save time when changing tips — no wrench needed. Resilient Graf-Tite® seat material protects tip from nicking and maintains positive seating. Requires less replacement than metal-to-metal seat designs.
- 2 Three-tube construction**  
Gases are kept separated, eliminating mixing tube burnout. Our thick-wall, high-capacity stainless steel tubes provide high gas flow and superior strength.
- 3 Ease-on cutting oxygen**  
Exceptionally smooth application of cutting oxygen reduces keyholing and slag blowback without sacrificing extremely high cutting capacity.
- 4 Reversible cutting lever**  
Top- or bottom-mount lever for ease of use.
- 5 Adjustable valve resistance**  
Special PTFE packing provides a gas-tight seal while allowing the “drag” to be adjusted to the individual preference.
- 6 Stainless steel ball-style valves**  
Provides smooth adjustment and positive seating.
- 7 Filtered replaceable hose connections**  
Connections are easily replaced if damaged. Filters keep debris from entering the cutting mechanism and high-pressure seat.

# Heavy-Duty Torches

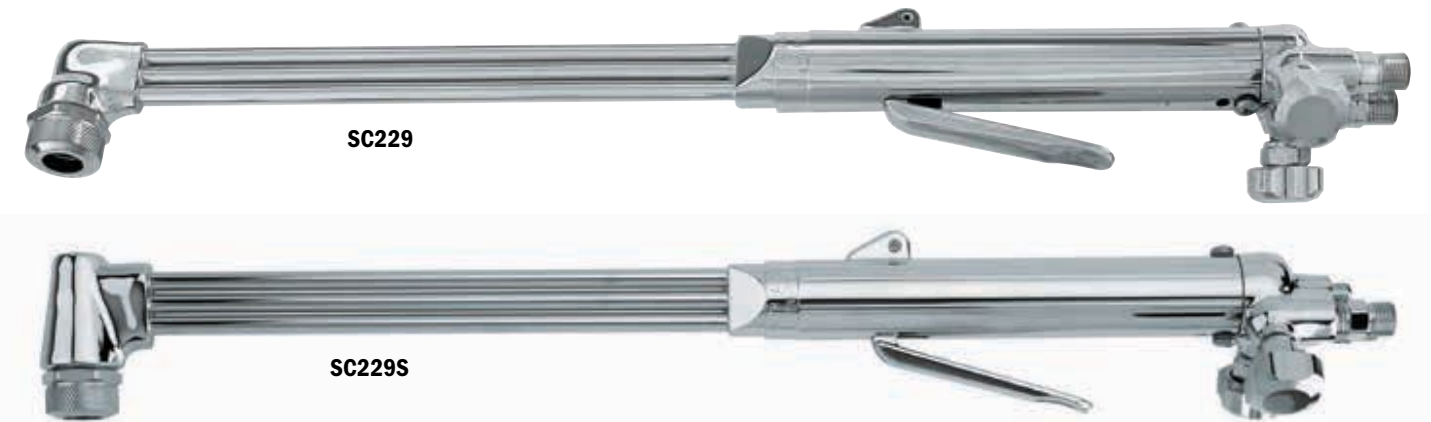

- SC175 and SC179**  
Length: 17 inches (432 mm)  
Weight: 2.6 lb. (1.18 kg)  
Head angle: 75 degrees (SC175)  
90 degrees (SC179)
- SC225, SC225S, SC229, SC229S and SC220**  
Length: 20.5 inches (521 mm) except SC220  
21 inches (533 mm) for SC220  
Weight: 2.7 lb. (1.22 kg)  
Head angle: 75 degrees (SC225 and SC225S)  
90 degrees (SC229 and SC229S)  
180 degrees (SC220)
- SC365, SC369 and SC360**  
Length: 36 inches (914 mm)  
Weight: 3.3 lb. (1.5 kg)  
Head angle: 75 degrees (SC365)  
90 degrees (SC369)  
180 degrees (SC360)
- Repair kit**  
SC100 (also for DG100, DG200 and DG300 Series)
- Valve assembly replacement**  
LW14B-1 (also for SW1 and DG200 Series)

## SC Series

Cuts up to 12-inch (305 mm) thick steel. Features sintered metal inlet filters, o-ring seating and easy-to-change slip-in Graf-Tite® cutting tips with cost-saving soft seats. Super-tough, thick-wall brass forged heads reduce warping and distortion. SC225S and SC229S have even thicker-walled heads for more severe service and applications. Use with any industrial fuel gases — acetylene, propane, natural gas, propylene, hydrogen, and many others. Several models of standard and special purpose tips are available for use in SC Series cutting torches. Cutting torches are covered by our lifetime warranty when used with authentic Miller | Smith tips.

## Cutting Tip Compatibility

Torch Number	Tip Compatibility (see pages 28–30)
All SC Series Torches	<b>Acetylene:</b> SC12-00 thru SC12-6, SC56-1 thru SC56-5
	<b>Propane and Propane-Based:</b> SC40-0 thru SC40-4, SC46-2 thru SC46-6, SC50-00 thru SC50-6
	<b>Propylene:</b> SC60-0 thru SC60-6, SC36-1 thru SC36-6
	<b>SC Series Special-Purpose Tips</b>



## 16229 Adjustable Circle Cutting Guide

Cutting range from 5/8 to 12-inch holes. Works with all hand cutting torches.





# Gas Axe™ Hand Cutting Torches

**Gas Axe™ extra-heavy-duty torches are 100-percent tested and inspected, and are ideal for scrap and demolition cutting.**

Safety engineered; designed for severe applications. Excellent for use with propane or natural gas. Works with all gases including propane/propylene-based fuels, natural gas and acetylene. Extra-high-capacity cuts up to 24 inches (610 mm) with acetylene. Cuts up to 20 inches (508 mm) with propane.

### Construction features

- 1 Thick-wall forged brass head**  
Super-tough, thick-walled head reduces heat warping and damage.
- 2 Slip-in cutting tips**  
Save time when changing tips – no wrench needed. Resilient Graf-Tite® seat material protects tip from nicking and maintains positive seating. Requires less replacement than metal-to-metal seat designs.
- 3 Three-tube construction**  
Gases are kept separated, eliminating mixing tube burnout. Our thick-wall, high-capacity stainless steel tubes provide high gas flow and superior strength.
- 4 Ergonomic handle**  
Thick, durable brass raised-rib handle for comfort and positive grip. Adds comfort and reduces operator fatigue.
- 5 Reversible cutting lever**  
Top- or bottom-mount lever for ease of use.
- 6 Adjustable valve resistance**  
Special PTFE packing provides a gas-tight seal while allowing the “drag” to be adjusted to the individual preference.
- 7 Ease-on cutting oxygen**  
Exceptionally smooth application of cutting oxygen reduces keyholing and slag blowback without sacrificing extremely high cutting capacity.
- 8 Stainless steel ball-style valves**  
For easy shut-off, smooth adjustment and positive seating.
- 9 Replaceable hose connections**  
Connections are easily replaced if damaged.

Stock Number	Head Angle in Degrees	Length Inches (mm)
SC929	90	21 (533)
SC935	75	36 (914)
SC939	90	
SC930	180	
SC945	75	48 (1219)
SC949	90	
SC940	180	
SC965	75	72 (1829)
SC969	90	
SC960	180	

Torch Repair Kit 15772  
Valve Assembly Replacement LW14B-1

### Cutting Tip Compatibility

Torch Number	Tip Compatibility (see pages 28–30)
All Gas Axe (SC900 Series) Torches	<b>Acetylene:</b> SC12-00 thru SC12-6, SC56-1 thru SC56-9 <b>Propane and Propane-Based:</b> SC40-0 thru SC40-4, SC46-2 thru SC46-6, SC50-00 thru SC50-9 <b>Propylene:</b> SC60-0 thru SC60-6, SC36-1 thru SC36-6 <b>Special-Purpose Tips:</b> SC2-2, SC2-4

### Recommended High-Flow Regulators

Torch Number	Recommended Regulator
All Gas Axe (SC900 Series) Torches	<b>Oxygen:</b> 40-175-540 or 40-275-540 (Cylinder), 46-175 (Manifold) <b>LP Gas:</b> 40-50-510 (Cylinder), 46-50 (Manifold)

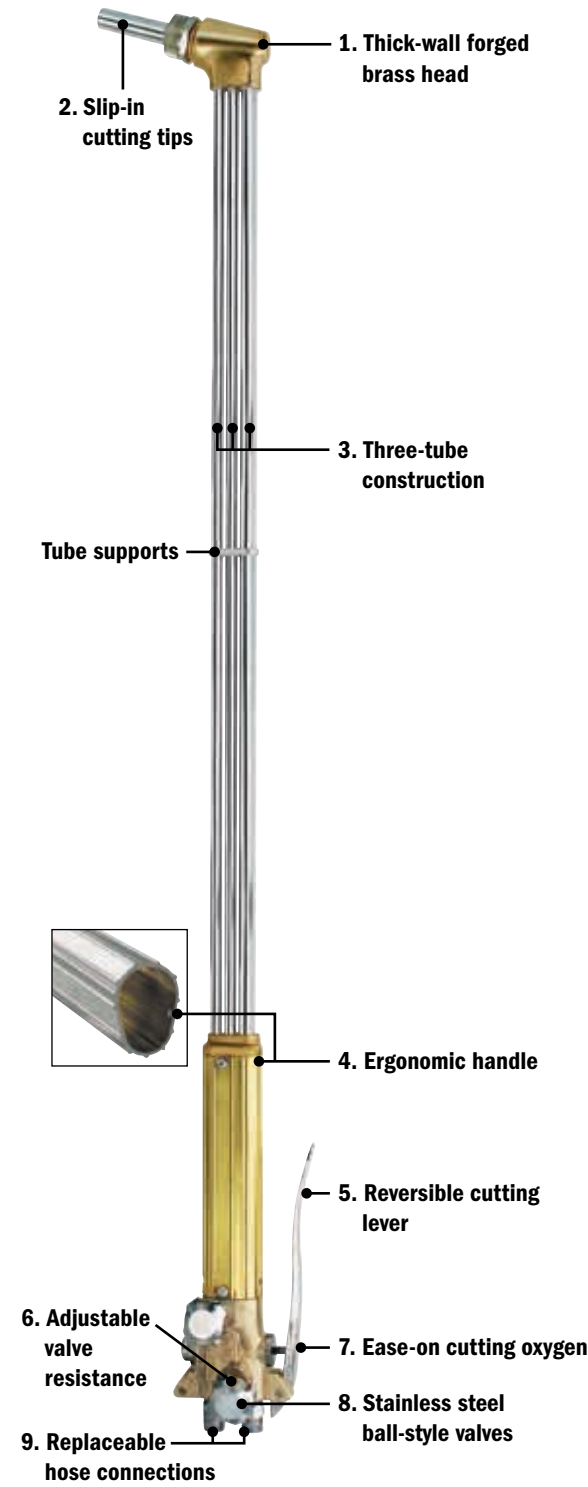

**CAUTION: Flashback arrestors**  
Gas Axe torches must be used in conjunction with high-flow flashback arrestors.

# Machine Cutting Torches

Our heavy-duty machine torches provide superior performance. Ease-on cutting lever reduces blowback in piercing and keyholing in restarts, extending tip life and providing high-quality precision cuts. Torch barrels easily adjust to four positions at 90-degree increments. Barrel diameters are 1-3/8 inches (9.5 mm) to fit most machines. Rack pitch is 32-10 teeth per inch. Stainless steel ball-type valves provide fine adjustment and positive shut-off.



Machine cutting torches are covered by our lifetime warranty when used with authentic Miller | Smith tips.

SC770 and SC772A two-hose machine cutting torches are industrial grade and capable of cutting up to 12 inches (305 mm) with acetylene, LP or natural gas. SC781A three-hose machine cutting torch is high capacity and capable of cutting up to 24 inches (610 mm) with acetylene and up to 20 inches (508 mm) with LP or natural gas.

	Stock Number	Stock Number (32 Pitch Rack only)	Overall Torch Length Inches (mm)
Two-Hose Models	SC770	4769-1 Rack*	8 (203)
	SC772A	15599 (Includes mounting screws)	13.75 (349)
Three-Hose Model	SC781A	SC781-1 (Includes mounting screws)	15.5 (394)

\*Requires stock number 4770 – two mounting screws.

Note: Overall length is measured from rear of hose connections to front of tip nut.

### Two-Hose Torches



SC770 two-hose torch      SC772A two-hose torch



### Three-Hose Torch



SC781A three-hose torch

### Cutting Tip Compatibility

Torch Number	Tip Compatibility (see pages 28–30)
Two-Hose Models SC770 and SC772A	<b>Acetylene:</b> SC12-00 thru SC12-6, SC56-1 thru SC56-9 <b>Propane and Propane-Based:</b> SC40-0 thru SC40-4, SC46-2 thru SC46-6, SC50-00 thru SC50-9 <b>Propylene:</b> SC60-0 thru SC60-6, SC36-1 thru SC36-6
Three-Hose Model SC781A	<b>Acetylene:</b> SC12 Series, SC56 Series <b>Propane and Propane-Based:</b> SC40-0 Series, SC46 Series, SC50 Series <b>Propylene:</b> SC60-0 Series, SC36 Series



### SC290 Bevel Cutting Attachment

Make bevel cuts without moving the angle of the torch. Bevel attachment makes bevel cuts up to 90 degrees either side of vertical. Compatible with our two- and three-hose machine torches.



Note: Cutting tip not included.



## Medium-Duty Single-Stage

### Series 30™



Sure-Seat™ filtered high-pressure seat assembly.

Series 30 regulator shown with H195 Hard Hat™ gauge/regulator guard.

### Rugged medium-duty industrial-grade regulators.

Series 30 single-stage regulators are extremely durable and contain our exclusive Sure Seat™ filtered seat technology for extended seat and regulator life. Filtered seats prevent contamination from entering the seating area, reducing repair costs and downtime. These highly accurate regulators are manufactured with a rugged forged body, corrosion-resistant bright nickel-plated bonnet and a highly durable neoprene composite diaphragm.

Stock Number	Gas	Delivery Pressure	Gauges (2 inch/51 mm)		Inlet Connection	Outlet Connection	Max Inlet Pressure
			Inlet	Outlet			
30-100-540	Oxygen	0-100 PSIG 0-7 Bar	4000 PSIG 276 Bar	150 PSIG 10 Bar	CGA 540	9/16"-18 RH "B"	3000 PSIG 207 Bar
30-20-540		0-20 PSIG 0-1 Bar		30 PSIG 2 Bar			
30-100-9 British fitting		0-100 PSIG 0-7 Bar	150 PSIG 10 Bar	G5/8"A-14 RH British fitting			
30-15-510	Acetylene	0-15 PSIG 0-1 Bar	400 PSIG 28 Bar	30 PSIG 2 Bar	CGA 510	9/16"-18 LH "B"	400 PSIG 28 Bar
30-15-300				CGA 300			
30-15-520				CGA 520			
30-15-200				CGA 200			
30-15-9 British fitting				G5/8"A-14 RH British fitting			
30-50-510	LP Gas (Propane, Propylene or Natural Gas)	0-50 PSIG 0-3 Bar	400 PSIG 28 Bar	60 PSIG 4 Bar	CGA 510	9/16"-18 LH "B"	400 PSIG 28 Bar
30-50-9 British fitting				G5/8"A-14 RH British fitting			
30-150-580	Argon/ Nitrogen	0-150 PSIG 0-10 Bar	4000 PSIG 276 Bar	200 PSIG 14 Bar	CGA 580	5/8"-18 RH Internal	3000 PSIG 207 Bar
30-100-320	CO <sub>2</sub>	0-100 PSIG	150 PSIG	10 Bar			
30-100-350	Hydrogen/ Methane	0-7 Bar			CGA 350	9/16"-18 LH "B"	

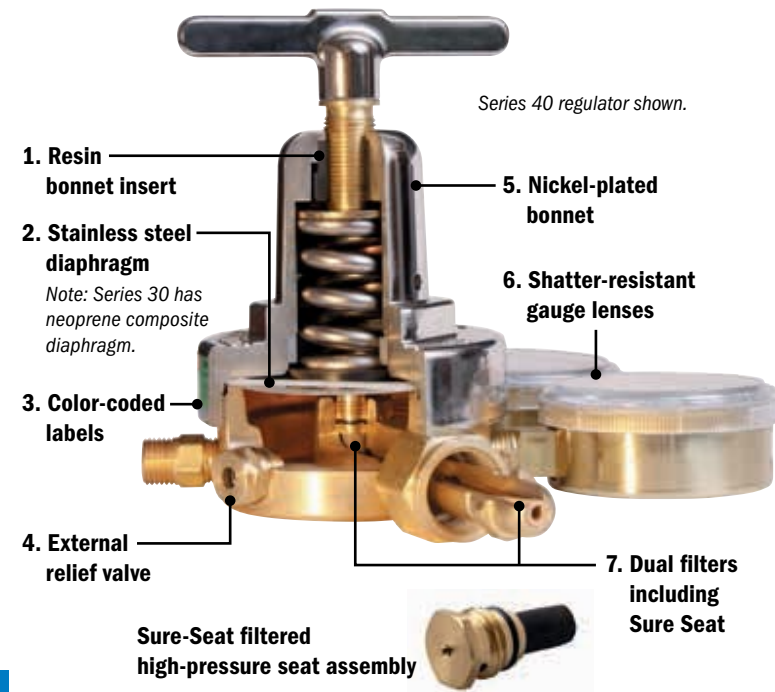

Series 40 regulator shown.

### Construction features

- 1 Resin bonnet insert**  
Allows smooth, easy adjustment even at high-pressure levels.
- 2 Stainless steel diaphragm**  
Resists corrosion, leaking and freeze-up if used with liquid (cryogenic) gases for extended service life.  
*Note: Series 30 has neoprene composite diaphragm.*
- 3 Color-coded labels**  
Supply performance capabilities, easy gas service identification and technical information.
- 4 External relief valve**  
Protects regulator from damage due to inadvertent high-pressure surge. Relief valve will release excessive pressure and automatically reset.
- 5 Nickel-plated bonnet**  
Along with brass body protect against corrosion.
- 6 Shatter-resistant gauge lenses**  
2.5-inch corrosion-resistant polished brass gauges with shatter-resistant polycarbonate lenses.  
*Note: Series 30 has 2-inch painted steel gauges.*
- 7 Dual filters including Sure Seat™**  
Protect high-pressure seat from debris for reliable operation and long service life.

Flow data may be obtained from [MillerWelds.com/flowdata](http://MillerWelds.com/flowdata)

#### Stock Number Definition (Example: 40-15-510)

- 40** Series
- 15** Maximum outlet pressure
- 510** Cylinder CGA connection

## Heavy-Duty Single-Stage



### Series 40™

#### Brass construction for dependable service in corrosive atmospheres.

Series 40 single-stage regulators comprise a complete line of versatile regulators for welding, cutting, heating and other industrial applications. Heavy-duty construction and simplified design provide high gas flow and longer trouble-free operation. Stainless steel diaphragm allows use with liquid gases.



Series 40 regulator shown with HB190 Hard Hat™ gauge/regulator guard.

Stock Number	Gas	Delivery Pressure	Gauges (2.5 inch/64 mm)		Inlet Connection	Outlet Connection	Max Inlet Pressure
			Inlet	Outlet			
40-175-540	Oxygen	0-175 PSIG 0-12 Bar	4000 PSIG 276 Bar	200 PSIG 14 Bar	CGA 540	9/16"-18 RH "B"	3000 PSIG 207 Bar
40-175-540S*		0-275 PSIG 0-19 Bar		400 PSIG 28 Bar			
40-275-540							
40-15-300	Acetylene	0-15 PSIG 0-1 Bar	400 PSIG 28 Bar	30 PSIG 2 Bar	CGA 300	9/16"-18 LH "B"	400 PSIG 28 Bar
40-15-300S*				CGA 510			
40-15-510							
40-15-510S*							
40-50-510	LP Gas (Propane, Propylene or Natural Gas)	0-50 PSIG 0-3 Bar	400 PSIG 28 Bar	60 PSIG 4 Bar	CGA 510	9/16"-18 LH "B"	400 PSIG 28 Bar
40-275-580	Nitrogen	0-275 PSIG 0-19 Bar	4000 PSIG 276 Bar	400 PSIG 28 Bar	CGA 580	5/8"-18 RH Internal	3000 PSIG 207 Bar

\*Includes HB190 Hard Hat gauge guard.

### Series 30™ Single-Stage Regulator Twin Packs



HTP2 – CGA 510 inlet connection for acetylene and LP cylinders  
HTP5 – CGA 300 acetylene inlet connection

### Feature benefits

- 1. Solid brass industrial construction**
- 2. Durable PTFE high-pressure seat**
- 3. Convenient and economical**
- 4. 100-percent tested and inspected**

Stock Number	Gas	Regulator	Specs
HTP2	Oxygen	30-100-540	Delivery Pressure: 0-100 PSIG Inlet Connection: CGA 540
	LP or Acetylene	30-15-510	Delivery Pressure: 0-15 PSIG Inlet Connection: CGA 510
HTP5	Oxygen	30-100-540	Delivery Pressure: 0-100 PSIG Inlet Connection: CGA 540
	Acetylene	30-15-300	Delivery Pressure: 0-15 PSIG Inlet Connection: CGA 300

## Two-Stage

### Series 30™



Series 30 two-stage regulators drop cylinder pressure to working pressure in two stages for consistent and accurate outlet pressure and flow regardless of inlet pressure. Recommended where outlet pressure and flow must be maintained without variation.

Stock Number	Gas	Delivery Pressure	Gauges (2 inch/51 mm)		Inlet Connection	Outlet Connection	Max Inlet Pressure
			Inlet	Outlet			
35-125-540	Oxygen	0-125 PSIG 0-9 Bar	4000 PSIG 276 Bar	150 PSIG 10 Bar	CGA 540	9/16"-18 RH "B"	3000 PSIG 207 Bar
35-15-510	Acetylene	0-15 PSIG 0-1 Bar	400 PSIG 28 Bar	30 PSIG 2 Bar	CGA 510	9/16"-18 LH "B"	400 PSIG 28 Bar
35-50-580	Inert	0-50 PSIG 0-3 Bar	4000 PSIG 276 Bar	60 PSIG 4 Bar	CGA 580	5/8"-18 RH Internal	3000 PSIG 207 Bar



## HVAC/Refrigeration Purge/Leak Test



Our single-stage nitrogen regulator is specially designed to meet the specifications of HVAC refrigerant purging applications. This regulator is used with nitrogen to test HVAC systems to locate leaks and to purge an area for installation and repair. Its compact size is suitable for use where space is limited.

- Economical and accurate
- Solid brass body provides durability
- Large durable nylon knob for easy pressure adjustment
- Highly accurate 2-inch (51 mm) gauges with shatter-resistant lenses
- Special option: Heavy-duty charging hose has 7/16"-20 RH connections with core (see page 38)

Stock Number	Gas	Delivery Pressure	Gauges (2 inch/51 mm)		Inlet Connection	Outlet Connection	Max Inlet Pressure
			Inlet	Outlet			
30-450-580	Nitrogen	0-450 PSIG 0-31 Bar	4000 PSIG 276 Bar	600 PSIG 41 Bar	CGA 580	7/16"-20 External Flair Fitting	3000 PSIG 207 Bar

## Single-Stage Station

### Series 46™ (Heavy-Duty) and Series 36™ (Medium-Duty)

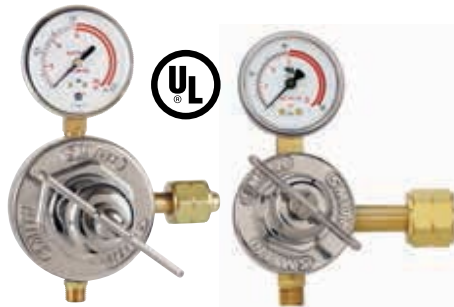

Series 46 and Series 36 brass line regulators are rugged, accurate and corrosion-resistant with shatter-resistant polycarbonate gauge lenses. The Series 46 regulators feature a stainless steel diaphragm and 2.5-inch (64 mm) gauges while the Series 36 has a neoprene composite diaphragm and 2-inch (51 mm) gauges.

Stock Number	Gas	Delivery Pressure	Gauges Diameter Inches (mm)	Inlet Connection	Outlet Connection	UL Listed Max Inlet Pressure
46-175	Oxygen	0-175 PSIG	2.5 (64)	CGA024	9/16"-18 RH "B"	200 PSIG / 14 Bar
36-150		0-12 Bar	2 (51)			500 PSIG / 35 Bar
46-15	Acetylene	0-15 PSIG	2.5 (64)	CGA025	9/16"-18 LH "B"	100 PSIG / 7 Bar
36-15		0-1 Bar	2 (51)			200 PSIG / 14 Bar
46-50	LP Gas	0-50 PSIG	2.5 (64)	CGA025	9/16"-18 LH "B"	100 PSIG / 7 Bar
36-50		0-3 Bar	2 (51)			500 PSIG / 35 Bar

Oxygen "C" size inlet connection CGA024 (7/8"-14 RH). Fits station valve NCG No. M960R, Rego. No. 7160.  
Fuel gases "C" size inlet connection CGA025 (7/8"-14 LH). Fits station valve NCG No. M961R, Rego. No. 7161.  
Note: Body inlet is 1/4-inch (6 mm) NPT.



## Heavy-Duty High-Pressure

### 820 Series



820 Series high-pressure regulators are for use on cylinders with a wide variety of non-corrosive inert gases. Piston-sensor design gives structural reliability in high-pressure use. Low-torque-control adjusting screw permits easy adjustment of pressures in closed or dead end systems.

Model Series	Delivery Pressure	Inlet Gauge (2.5 inch/64 mm)		Outlet Gauge (2.5 inch/64 mm)		Max Inlet Pressure
		Range	Graduations	Range	Graduations	
823	0-500 PSIG	0-10,000 PSIG	200 PSIG	0-1000 PSIG	100 PSIG	6000 PSIG
824	0-1000 PSIG			0-4000 PSIG		
825	0-2000 PSIG			0-4000 PSIG		
826	0-4000 PSIG			0-6000 PSIG		
827	0-6000 PSIG			0-6000 PSIG		

#### Typical applications

- High-pressure testing
- Purging and charging
- Calibration kits
- Airline charging carts
- Chemical plants
- Manufacturing processes
- Research and development
- Laboratories

#### Model Configuration

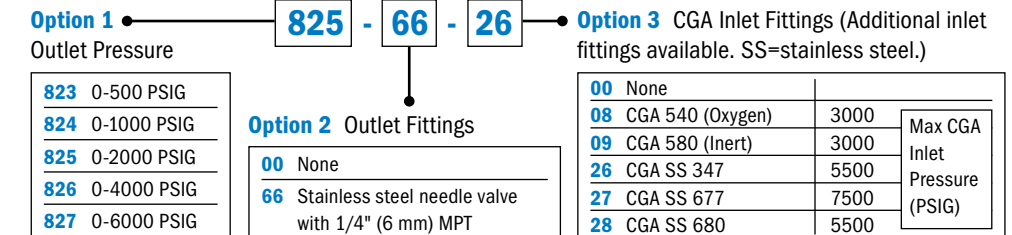

## Three-Stage Nitrogen Low-Pressure Blanketing



This preset regulator is specially designed to deliver a highly accurate and consistent low-pressure supply of nitrogen to oil-filled power transformers. Available with or without electronic pressure switch. The regulator will deliver and maintain 0.50 PSIG in the head space of oil-filled transformers. A built-in self-relieving valve set at 8 PSIG protects the system from over-pressurization due to temperature variation. Both models come with rapid-fill bypass pressure valve allowing rapid filling of the transformer with 6 PSIG of pressure.

Stock Number	Preset Outlet Pressure			Bypass Rapid Fill/Purge	Inlet Connection	Outlet Connection	Max Inlet Pressure
	1st Stage	2nd Stage	3rd Stage (delivery pressure) into outlet				
16391 (without pressure switch)	150 PSIG	8 PSIG into 3rd stage	0.4-0.6 PSIG into outlet	6 PSIG	CGA580	1/2" FNPT	3000 PSIG
16347-3 (with pressure switch)	PSIG into 2nd stage						

Note: Operation temperature: -40° to +180° Fahrenheit.  
Operation voltage (model 16347-3): 5 amps at 12/24 volts DC or 125 volts AC. 3 amps at 250 volts.  
Pressure switch setting: Adjustable from 70-300 PSIG (ships preset at 250 PSIG), 3/32-inch Allen head screw switch.  
Switch wiring: Normally open or normally closed (DPDT), three 18-inch flying leads.



## Rear-Entry Liquid Cylinder

### 250 Series



#### Features

- Rear-entry connection provides clearance of liquid cylinder ring allowing easier gauge reading
- Easy-to-read single-scale 2.5-inch gauge
- Ideal for non-corrosive high-purity applications
- Nickel-plated brass body for corrosion resistance
- Large 1-7/8-inch SST diaphragm for precise control of pressure
- Easy-to-adjust hand knob

Note: Use Series 40™ heavy-duty regulators constructed with a stainless steel diaphragm for high-volume or liquid (cryogenic) cylinder applications.



Due to specific configurations, we cannot accept returns of 250 Series regulators.

Model Series	Delivery Pressure	Outlet Gauge (2.5 inch/64 mm)		Max Inlet Pressure
		Range	Graduations	
252	0-100 PSIG	0-200 PSIG	5 PSIG	3500 PSIG
254	0-200 PSIG	0-400 PSIG	10 PSIG	
255	0-350 PSIG	0-400 PSIG	10 PSIG	
256	0-500 PSIG	0-1000 PSIG	20 PSIG	

#### Model Configuration

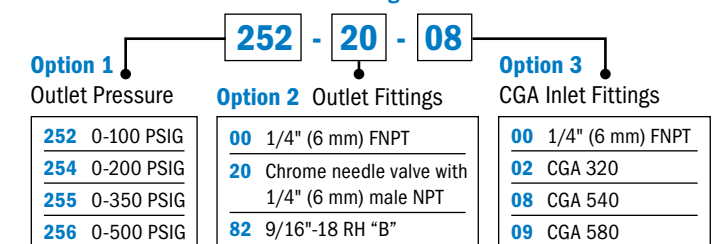

## Flowmeter Regulators



**Our flowmeter regulators are 100-percent tested and inspected, and provide unmatched gas control and accuracy.**

Flowmeter regulators are available in multiple scales for use with all major shielding gases to cover most MIG or TIG welding applications. Our premium flowmeter regulators feature an exclusive self-centering ball guide which provides accurate readings even if tipped. This ensures optimum weld quality and gas savings. Others use a non-self-centering flow tube ball that tends to float off center causing actual gas flow to be over two times greater than indicated.



Regulators are covered by our 3-year limited warranty.

### Premium flowmeter regulator construction features

- 1 Protective housing**  
Flow tubes are protected from accidental damage while offering unobstructed view of flow reading.
  - 2 Extra-long flow tube**  
Expanded scales are easy to read and accurate within five percent of full reading. Can be attached to regulators or pipeline installations.
  - 3 Shatter-resistant multi-scale flow tube**  
Tubes are made of shatter-resistant polycarbonate resin and feature multiple scales.
  - 4 Sure Seat™ filtered high-pressure seat assembly**  
Protects high-pressure seat from debris for reliable operation and long service life.
  - 5 Auto-reset pressure-relief valve**  
Protects regulator from damage due to inadvertent high-pressure surge. Relief valve will release excessive pressure and automatically reset.
- Selec-O-Gas™ flowmeter regulator (option)**  
Four separate, easy-to-read scales for argon and argon/CO<sub>2</sub> mix, CO<sub>2</sub>, helium and a general scale for other non-corrosive gases. Rotate outer tube to desired scale.

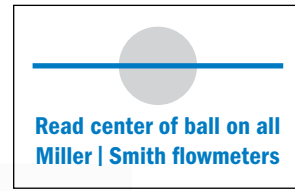

Regulators

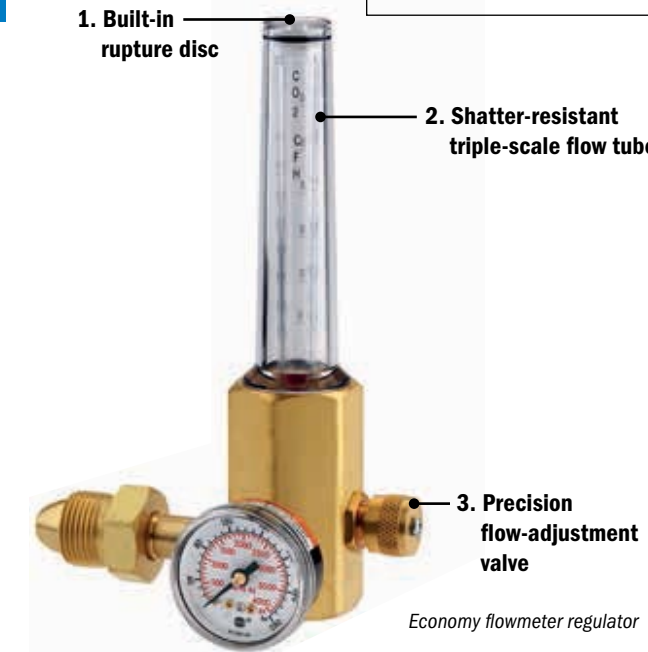

### Economy flowmeter regulator construction features

- 1 Shatter-resistant triple-scale flow tube**  
Tubes are made of shatter-resistant polycarbonate resin and can be rotated to position desired scale for easy reading. Scaled for CO<sub>2</sub>, argon and argon/CO<sub>2</sub> mix, and helium.
- 2 Built-in rupture disc**  
Reduces possibility of flow tube damage due to inadvertent high-pressure surge. Must be replaced if ruptured – not auto-resetting.
- 3 Precision flow-adjustment valve**  
Allows easy adjustment to desired setting.

Flow data may be obtained from [MillerWelds.com/flowdata](http://MillerWelds.com/flowdata)

**Stock Number Definition (Example: 32-80-580)**  
**32** Series  
**80** Maximum outlet pressure  
**580** Cylinder CGA connection

## Premium Flowmeter Regulators



### Series 30™



Rugged medium-duty industrial-grade regulators provide efficient and accurate regulation, and include our exclusive self-centering flowball. They are constructed with our exclusive Sure Seat™ filtered seat technology for extended seat and regulator life. Filtered seats prevent contamination from entering the seating area, reducing repair costs and downtime. Filtered seats also reduce CO<sub>2</sub> freeze-up. Provides high argon flow capacity up to 80 SCFH.

Stock Number*	Flowmeter	Gas	Flow Range	Preset Delivery Pressure	Inlet Connection	Outlet Connection	Max Inlet Pressure
32-80-580	H1105	Argon, CO <sub>2</sub>	10-80 SCFH 5-38 LPM	80 PSIG 6 Bar	CGA 580	5/8"-18 RH Internal	3000 PSIG 207 Bar
32-80-320		CO <sub>2</sub>			CGA 320		
32-30-580 Selec-O-Gas**	H1240	Argon, CO <sub>2</sub>	10-60 SCFH 5-28 LPM	30 PSIG 2 Bar	CGA 580	5/8"-18 RH Internal	3000 PSIG 207 Bar
		Helium	20-190 SCFH 10-90 LPM				
		General/ Any Gas	0-10 Range Scale				
35-30-320	H1240	CO <sub>2</sub>	10-80 SCFH 5-38 LPM	30 PSIG 2 Bar	CGA 320	5/8"-18 RH Internal	3000 PSIG 207 Bar

\*Add "-6" to end of part number to include 6-ft. x 1/4-inch inert gas hose.

\*\*Selec-O-Gas™ regulator does the job of more than three common flowmeters. Features four separate scales: argon, CO<sub>2</sub>, helium and general gas which allows the use of several different non-corrosive gases.

Note: When using argon/CO<sub>2</sub> mix, read argon scale.

## Economy Flowmeter Regulators (Single-Stage)



### H2051 Series



Exceptional value and compact design. Provides precise shielding gas regulation for MIG and TIG welding applications and more. Shatter-resistant polycarbonate flow tube is repositionable for easy reading and features triple-scale for argon, helium and argon/CO<sub>2</sub>. It has a packless o-ring flow tube seal which reduces maintenance and a built-in rupture disc reduces possibility of flow tube damage due to high-pressure inlet surge. Precision flow-adjustment valve allows easy adjustment to desired setting.

Stock Number	Gas (3 Scales)	Flow Range	Preset Delivery Pressure	Inlet Connection	Outlet Connection	Max Inlet Pressure
H2051B-580	CO <sub>2</sub>	0-50 SCFH 0-24 LPM	50 PSIG 3 Bar	CGA 580	5/8"-18 RH Internal	3000 PSIG 207 Bar
H2051B-580H*				G5/8"A-14 RH		
H2051B-B9 British fitting	Helium	0-160 SCFH 0-78 LPM		British fitting on H2051A-B9		
	Argon, Argon/CO <sub>2</sub> Mix	0-60 SCFH 0-28 LPM				

\* Includes 6-ft. (1.8 m) hose with inert hose fittings.

Note: When using argon/CO<sub>2</sub> mix, read argon scale.

## Dual Flowmeter Regulator (Single-Stage)



### Series 30™



Dual flowmeter regulator has a back-pressure compensated flow tube with shatter-resistant polycarbonate cover. It is repositionable for easy reading and features triple scale for argon, helium and argon/CO<sub>2</sub>. Features include sensitive needle valve for fine adjustment and a 2-inch (51 mm) gauge.

Stock Number	Flowmeter	Gas (3 Scales)	Flow Range	Preset Delivery Pressure	Inlet Connection	Outlet Connection	Max Inlet Pressure
33A-50-580	H2230A	CO <sub>2</sub>	0-50 SCFH 0-24 LPM	50 PSIG 3 Bar	CGA 580	5/8"-18 RH Internal	3000 PSIG 207 Bar
		Helium	0-160 SCFH 0-78 LPM				
		Argon, Argon/CO <sub>2</sub> Mix	0-60 SCFH 0-28 LPM				

Note: When using argon/CO<sub>2</sub> mix, read argon scale.

Regulators

## Flowmeters



### Premium Heavy-Duty

Premium flowmeter models are designed to operate at inlet pressures of 80 PSIG (model H1105) and 30 PSIG (Selec-O-Gas model H1240). They can be attached to regulators or pipeline installations. Features include an extra-long flow tube made of shatter-resistant polycarbonate resin that is accurate to within five percent of the full scale reading. Flow tubes have a unique ball guide which centers the ball in the tube and keeps it centered (competitors use a ball floating in a non-centering tube which allows the ball to float off-center resulting in greater flows than the reading indicates). Our exclusive Selec-O-Gas™ flow tube has separate scales for argon, CO<sub>2</sub>, helium and general non-corrosive gas. Just rotate the outer tube to the scale you desire.



	Stock Number	Tube Number	Gas	Flow Range	Inlet Connection	Outlet Connection	Recommended Inlet Pressure
Heavy-Duty Flowmeters	H1105*	13220	Argon, CO <sub>2</sub>	0-80 SCFH 0-38 LPM	1/4" NPT Male	5/8"-18 RH Internal	80 PSIG 6 Bar
	H1240 Selec-O-Gas*	14254	Argon, CO <sub>2</sub> , Helium, General	10-80 SCFH 5-38 LPM	1/4" NPT Male	5/8"-18 RH Internal	30 PSIG 2 Bar
Standard-Duty Flowmeters	H2230A Multi-Scale	N/A	CO <sub>2</sub>	0-50 SCFH 0-24 LPM	1/4" NPT Male on H2230	5/8"-18 RH Internal	50 PSIG 3 Bar
			Helium	0-160 SCFH 0-78 LPM	5/8"-18 RH External on H2231		
	H2231A Multi-Scale	Argon, Argon/ CO <sub>2</sub> Mix	0-60 SCFH 0-28 LPM				

\*H1105 supersedes H1103; H1240 supersedes H1230E.  
Note: When using argon/CO<sub>2</sub> mix, read argon scale.

### Standard-Duty

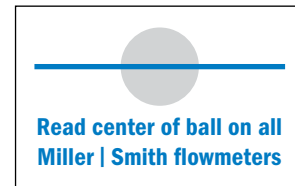

**CAUTION:** Do not connect flowmeters directly to gas cylinder.

## Single-Stage Flow Gauge Regulators



### Series 30™

Single-stage flow gauge regulators are compact and feature a forged brass body with 2-inch diameter gauges and a self-reseating pressure relief valve. They also include a Sure Seat™ protective inlet filter and a durable neoprene-composite diaphragm.



Stock Number	Gas	Flow Range	Gauges (2 inch/51 mm)		Inlet Connection	Outlet Connection	Max Inlet Pressure
			Inlet	Outlet			
31-50-580	Argon	10-50 SCFH	0-4000 PSIG	10-50 SCFH	CGA 580	5/8"-18 RH Internal	3000 PSIG 207 Bar
31-50-580-6*					CGA 320		
31-50-320	CO <sub>2</sub>						
31-50-9 British fitting	Argon				G5/8"A-14 RH British fitting		

\*Comes with 6-ft. x 1/4-inch inert gas hose.

## Fixed-Flow Adaptors and Surge Protectors

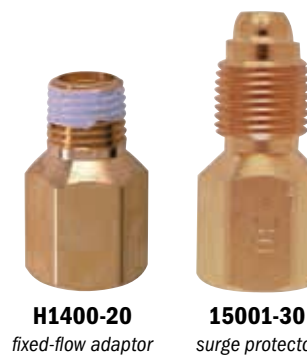

H1400-20 fixed-flow adaptor  
15001-30 surge protector

### H1400 Series Fixed-Flow Adaptors

Designed for welding operations or other applications requiring fixed gas flows. Installs in regulator outlet or directly on 30 PSIG pipeline outlet without regulator. Set regulator at 30 PSIG and be assured of correct gas flow. Inlet filter protects orifice from debris. Female thread size 5/8"-18 UNF, male thread size 1/4-inch (6 mm) NPT.

### 15001 Series Surge Protectors

Fixed-flow surge protectors designed for MIG welding applications eliminate sudden surges of shielding gas into the wire feeder. Flows listed are at 30 PSIG inlet pressure. Female thread size 5/8"-18 UNF, male thread size 5/8"-18 UNF (connects directly to wire feeder or welder).



Surge Protector

Fixed Flow Adaptors	Stock Number	Flow (SCFH) @ 30 PSIG Inlet Pressure							Orifice Diameter
		CO <sub>2</sub>	Air	Argon	Helium	Nitrogen	Hydrogen	Oxygen	
Fixed Flow Adaptors	H1400-20	20	24	21	65	25	91	23	.026
	H1400-30	30	37	32	100	38	140	35	.032
	H1400-40	39	48	41	129	49	182	46	.037
	H1400-50	50.5	62	53	167	63	234	59	.042
Surge Protectors	15001-20	20	24	21	65	25	91	23	.026
	15001-30	30	37	32	100	38	140	35	.032
	15001-40	39	48	41	129	49	182	46	.037

## Premium-Quality Gauges

### Replacement Gauges

Pressure gauges (PSI/Bar) and flow gauges (CFH/LPM) have dual scale readings and are manufactured in accordance with our rigid quality standards. All gauges feature precision watch-type movements for optimum accuracy and 1/4-turn lens rings. They also feature one-piece shatter-resistant polycarbonate lenses with protective lips to prevent damage to the high-visibility cupped faces.



GA033-07  
2.5-inch (64 mm)  
brass gauge



GA134-03  
2-inch (51 mm)  
gauge

Note: All gauges have 1/4-inch (6 mm) NPT bottom stem.

Brass Case Gauges (2.5 inch/64 mm)	
Stock Number	Pressure Calibration
GA026-07 Red zone	30 PSI/2 Bar
GA029-07	60 PSI/4 Bar
GA033-07	200 PSI/14 Bar
GA037-07	400 PSI/28 Bar
GA043-07	4000 PSI/280 Bar

Black Case Gauges (2 inch/51 mm)	
Stock Number	Pressure Calibration
GA136-03	50 CFH/25 LPM
GA134-03 Red zone	30 PSI/2 Bar
GA141-03	30 PSI/2 Bar
GA135-03	60 PSI/4 Bar
GA143-03	100 PSI/7 Bar
GA137-03	150 PSI/10 Bar
GA140-03	200 PSI/14 Bar
GA138-03	400 PSI/28 Bar
GA142-03	600 PSI/40 Bar
GA139-03	4000 PSI/280 Bar
GA145-03	6000 PSI/400 Bar



16266 Electronic Alarm Gauge

This device is designed to send an alarm alerting the operator when the pressure from the cylinder into the regulator falls below a designated level. The alarm switch has an adjustable range of 50-450 PSI (3-31 Bar). It is factory preset at 250 PSI (17 Bar). 2.5-inch (64 mm) gauge has a maximum inlet pressure of 3500 PSI (241 Bar). Three-lead switch wiring: normally open or normally closed (DPDT). **NOT for use with oxygen.**

Note: See Three-Stage Nitrogen Low-Pressure Blanketing Regulator on page 20 for more detailed information.

## Proportional Standard Two-Gas Mixer



299-006-1C

Stock Number	Gas	Adjustment % Range	Flow Range	Inlet and Outlet Connections	Required Inlet Pressures	Outlet Pressure Without Flow
299-006-1C	Argon/CO <sub>2</sub>	0-100% 100%-0	10-180 SCFH	5/8"-18 RH Internal	105-115 PSIG 7.3-7.9 Bar	50 PSIG 3.5 Bar

**3291 Mixer Inlet Filters** (mixer protection only). 60 micron nominal.  
Note: Outlet pressure factory set at no flow. All gases used with the mixers must be compatible with Buna-N, Copolymer Acetal, Nylon and Polyethylene.

- Requires no electricity
- Dimensions
  - Height: 7.5 in. (191 mm)
  - Width: 5.5 in. (140 mm)
  - Depth: 10.5 in. (267 mm)
- Weight: 7.6 lb. (3.45 kg)

### Accurate TIG and MIG weld shielding gas mixing

Various welding processes require different gas mixes for the best performance. Our proportional gas mixer provides accurate mixing ( $\pm 2\%$  of scale), and allows custom mixtures for producing optimal welds. Convenient chart on top provides proper settings for argon/CO<sub>2</sub>, argon/helium, argon/oxygen and CO<sub>2</sub>/oxygen.

### Easy operation, training and supervision in welding applications

Whether you are using a single welder or a manifold system supplying many welders, operation is simple and easy to use. Ideal for training all personnel regarding shielded gas mixtures because they can see the effect of various gas mixtures on weld appearance, quality and penetration.

### Eliminates stocking and handling pre-mixed gases

On-site mixing of gases with our proportional gas mixer eliminates stocking and handling of costly premixed gases. Individual gases can be mixed for specific welding or other industrial requirements resulting in improved performance.

### Reduces set-up time

No need to change cylinders, regulators, flowmeters or hoses when changing from one range of mixed gas to another. Just turn the dial for whatever mixture you need.

### No gas separation!

Pre-mixed gases may separate (stratify) into the individual gases within the cylinder. Our proportional gas mixer eliminates gas stratification to always give you an accurate mixture.

Mixers may be shipped to Miller for recalibration, reconditioning and gas mix certification. Contact customer service at 1-800-426-4553 to obtain information on costs and return goods instructions.

# Tips

## Cutting Tips

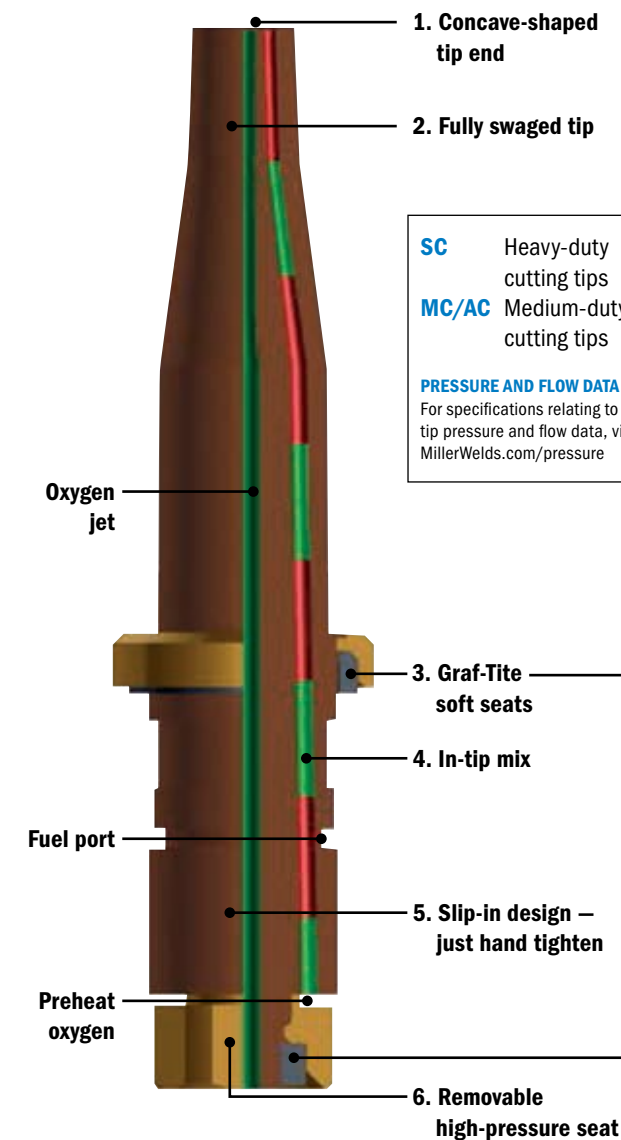

**Our tips are 100-percent tested and inspected and are the longest lasting tips you can buy.**

Whatever your application, whatever your fuel gas, we have a tip that provides fast, economical and quality cutting. Select the tip to match the job. It's faster, gives a cleaner cut, cuts expensive labor time, and saves on cleanup, machining and gas. Select from quality tips for dependable performance with acetylene, natural gas (city gas), propane and propylene-based fuels.

Authentic Miller | Smith tips must be used. To qualify for warranty repair, Miller | Smith torches *must be returned with tip*. Aftermarket tips are often the cause of poor performance or malfunction.

### Construction features

- Concave-shaped tip end**  
Reduces backfire and resists flameout when making accidental contact with base metal during cutting operations.
- Fully swaged tip**  
Mirror-smooth gas passages minimize turbulence to deliver stable gas flows for fast starts and precision cuts. Also minimizes slag build-up and reduces clean-up time.
- Graf-Tite® soft seats**  
Resilient Graf-Tite® seat material protects tip seating areas from nicking to maintain positive seating. Requires less replacement than metal-to-metal seat designs. Compressible soft seats are practically indestructible and withstand extremely high temperatures, resulting in longer tip life.
- In-tip mix**  
Each tip is a precision engineered mixer for combining preheat oxygen and fuel gas to attain maximum efficiency. Adds resistance to flashback.
- Slip-in tip design – just hand tighten**  
After the first tightening with a wrench, only hand tightening is required to seat the tip, saving time when changing tips. Quick and easy tip changes encourage use of right tip for the job.
- Removable high-pressure seat**  
Allows cleaning from back of tip.

### Fuel Gas Chart

Generic Name	Trade Name
Acetylene	—
Propane and Propane-Based Mixtures	Propane-butane, Flamex, Acetogen, Chem-O-Lene, Florida Industrial Gas, Hy-Temp, Fuel Gas, I.G. Gas, Chem-Gas, Lingas, Chemtone
Propylene	HPG, Apachi, B-Plus, Gulf HP Gas, HEF, Liquifuel, B.T.U.
Natural Gas (Methane)	Natural Gas, City Gas

### Tip Usage Chart

Tip Series	Applications and Characteristics
SC12, MC12	General cutting operations, medium preheat.
SC46, SC36	Dirty, heavily coated metal. Rugged use (scrapping, heavy construction). Used where excessive reflected heat is present.
SC56	Dirty, coated metal. Heavy preheat for faster starts. CAUTION: Manifolding may be necessary for large tips with acetylene.
SC50	Coated metal. Heavy preheat for faster starts. Excellent for scrapping.
SC40, SC60 MC40, MC60	General cutting operations, medium preheat.

**CAUTION: Liquid oxygen**  
When using liquid oxygen, tips may require greater gas volume than a single cylinder is capable of producing. External evaporators or manifolding multiple cylinders may be necessary to supply sufficient gas flows.

**CAUTION: Manifolding cylinders**  
When required flows (cubic feet per hour – SCFH) exceed the recommended withdrawal rate from one cylinder, then additional cylinders must be manifolding to provide safe and efficient operation.

**CAUTION: Hoses**  
Do not use excessively long hoses or hoses with many hose unions; either will restrict gas flow and pressure causing lower cutting efficiency and possibly leading to dangerous operating conditions.



# Heavy-Duty Special-Purpose Tips

Acetylene



### Extra Long Cutting SC12-4X9

Tip for hard-to-reach areas. Size 4.

### Gouging SC13-3 and SC13-5

For edge preparation, removal of welds or gouging cracked metals.

### Rivet/Riser Cutting SC14-3

Cuts heads of bolts and rivets. It can also be used in 180-degree head cutting torch to cut out boiler tubes. Works equally well for cutting risers and bulk heads.

### Rivet Blowing and Metal Washing – SC15-2

Quickly removes large quantities of metal. Heavy preheat primarily used as a rivet blowing tip, but can be used for stud removal, metal washing, gouging, veeing and groove cutting.

### Plate Cutting – SC17-0

“Drag”-style step tip cuts thin sheet metal with absolute minimum burn over and plate warpage.

### Heating – SC83

Delivers large volume of heat quickly for bending, straightening, shrinking, forming and other heating applications. It allows heating with a one-piece cutting torch. *Not recommended for use with cutting attachments.*

Tip Number	Purpose	Capacity Inches (mm)	Consumption (SCFH)	
			Oxygen	Acetylene
SC12-4x9	Cutting	4 (102)	331	14
SC13-3	Gouging	3/8 (10) wide 1/4 (6) deep	151	35
SC13-5	Gouging	1/2 (13) wide 3/8 (10) deep	246	50
SC14-3	Riser	1-1/2 (38) rivets	190	20
SC15-2	Washing	1/2 (13) wide 3/8 (10) deep	336	40
SC17-0	Plate or Thin Cutting	3/8 (10)	55	4

Tip Number	Purpose	Average BTU/Hour	Consumption (SCFH)	
			Oxygen	Acetylene
SC83	Heating	83,000	58	52*

\*Two 350-cu.-ft. cylinders required.

### Compatible cutting attachments and torches

- SC200 and DG200 Series attachments (except SC83)
- All SC and DG Series hand torches and machine torches

# Medium-Duty and Standard-Duty Tips

## MC12 Series



Slip-in cutting tips for general medium-duty hand cutting. Use with medium pressure acetylene and oxygen.

### Compatible cutting attachments

- MC509, CC509P, DG109A, AC309 (AC309: maximum size MC12-4)

Tip Number	Metal Thickness Inches (mm)	Consumption (SCFH)			Drill Size Cutting Jet
		Oxygen		Acetylene Preheat	
		Cutting	Preheat		
MC12-00	1/8 (3)	30	7	6	68
MC12-00	3/16 (5)	30	7	6	68
MC12-0	1/4 (6)	40	7	6	62
MC12-0	3/8 (10)	46	7	6	62
MC12-1	1/2 (13)	75	9	7	55
MC12-1	5/8 (16)	81	9	7	55
MC12-2	3/4 (19)	107	11	9	54
MC12-2	1 (25)	118	11	9	54
MC12-3	1-1/2 (38)	170	12	10	51
MC12-3	2 (51)	181	12	10	51
MC12-4	2-1/2 (64)	249	14	12	45
MC12-4	3 (76)	267	14	12	45
MC12-4	4 (102)	320	15	13	45
MC12-5	5 (127)	420	15	13	41
MC12-5	6 (152)	485	15	13	41

## MC13-3 Gouging



For edge preparation, removal of old welds or defects in steel. Heavy preheat.

### Compatible cutting attachments

- MC505, MC509, CC509P, AC309 and DG109A

Tip Number	Purpose	Capacity Inches (mm)	Consumption (SCFH)	
			Oxygen	Acetylene
MC13-3	Gouging	3/8 (10) wide 1/4 (6) deep	115	24*

\*One 350-cu.-ft. cylinder required.

## MC40 Series (Two-Piece)



Two-piece medium preheat cutting tips for hand cutting with propane and propane-based fuel gases.

### Compatible cutting attachments

- MC505, MC509, CC509P, AC309 and DG109A

Tip Number	Metal Thickness Inches (mm)	Consumption (SCFH)			Drill Size Cutting Jet
		Oxygen		Propane Preheat	
		Cutting	Preheat		
MC40-00	3/16 (5)	24	35	7	68
MC40-0	1/4 (6)	40	35	7	62
MC40-0	3/8 (10)	46	35	7	62
MC40-1	1/2 (13)	75	35	7	55
MC40-1	5/8 (16)	81	35	7	55
MC40-2	3/4 (19)	107	35	7	54
MC40-2	1 (25)	118	35	7	54
MC40-2	1-1/4 (32)	133	35	7	54
MC40-3	1-1/2 (38)	170	35	7	51
MC40-3	2 (51)	181	35	7	51
MC40-4	2-1/2 (64)	249	35	7	51
MC40-4	3 (76)	267	35	7	51
MC40-4	4 (102)	320	35	7	51

See data note at right.

## MC60 Series (Two-Piece)



Two-piece medium preheat cutting tips for hand cutting with propylene or propylene-based fuel gases.

### Compatible cutting attachments

- MC505, MC509, CC509P, AC309 and DG109A

Tip Number	Metal Thickness Inches (mm)	Consumption (SCFH)			Drill Size Cutting Jet
		Oxygen		Propylene Preheat	
		Cutting	Preheat		
MC60-1	1/2 (13)	75	26	7	55
MC60-1	5/8 (16)	81	26	7	55
MC60-2	3/4 (19)	107	26	7	54
MC60-2	1 (25)	118	26	7	54
MC60-2	1-1/4 (32)	133	26	7	54
MC60-3	1-1/2 (38)	170	42	11	51
MC60-3	2 (51)	181	42	11	51
MC60-4	2-1/2 (64)	249	42	11	45
MC60-4	3 (76)	267	42	11	45
MC60-4	4 (102)	320	42	11	45

Data based on 25-ft. (7.6 m) of 3/16-in. (5 mm) ID hose for cutting up to 1-1/2-inch (38 mm) steel and 25-ft. (7.6 m) of 1/4-in. (6 mm) ID hose for cutting 2-in. (51 mm) steel and above.

Propane or Natural Gas Propylene



### General Gouging (Propane) SC2-2 and SC2-4

For removing old welds or cracks, veeing and groove cutting.



### Heavy-Duty Gouging SC23-3 (Propane) SC23-3M (Propylene)

For removing old welds or cracks, veeing and groove cutting.



### Heating (Propane) SC112

Provides lots of heat fast with economical LP gas and oxygen. *Not recommended for use with cutting attachments.*

Tip Number	Purpose	Capacity Inches (mm)	Consumption (SCFH)	
			Oxygen	Fuel
SC2-2	Gouging	5/16 (8) wide 1/8 (3) deep	389	53
SC2-4	Gouging	3/8 (10) wide 1/4 (6) deep	564	53
SC23-3	Gouging	3/8 (10) wide 1/4 (6) deep	174	31
SC23-3M	Gouging	1/4 (6) wide 3/8 (10) deep	174	31

Tip Number	Purpose	Average BTU/Hour	Consumption (SCFH)	
			Oxygen	Propane
SC112	Heating	289,000	495	125*

\*Two 100-lb. cylinders required.

### Compatible cutting attachments and torches

- SC200 and DG200 Series attachments (except SC112)
- All SC and DG Series hand torches and machine torches



# Welding Tips



1. "Soft flame"

2. Heavy-wall copper

**SW** Heavy-duty welding and brazing tips  
**MW** Medium-duty welding and brazing tips  
**AW** Standard-duty welding and brazing tips (Airline)

Individual mixers

3. Slip-in tips

4. O-ring seals

In-tip mix

Our "soft flame" welding tips are 100-percent tested and inspected, and make welding easier.

Our welding tips are quality engineered to provide easy handling, high performance and added protection in welding, brazing and soldering operations. Each tip is individually tested on our automatic testing machines and must pass stringent requirements for flame characteristics, gas flow and resistance to backfire or flashback.

### Construction features

- "Soft flame"**  
Our "soft flame" welding tips provide concentrated heat for better "puddle" control – the turbulent-free flame eliminates puddle chasing. Soft flame provides deep, even penetration without burning through base metal for strong, dependable welds. Molten metal is protected from atmospheric oxidation by smooth, even flame envelope.
- Heavy-wall copper**  
Heavy-wall copper gives greater resistance to reflected heat, permits cooler operation, and dissipates more heat than thin-wall copper. Heat-absorbing tips provide longer life, and the long straight-away design permits tip refacing after excessive wear or abuse.
- Slip-in tips**  
Tips may be rotated 360 degrees for convenient positioning, eliminating hose resistance during operation. Slip-in tips can be changed in just seconds. Hand tighten, no wrench needed. O-rings provide gas-tight seal keeping gases separate until they mix in the tip.
- O-ring seals**  
O-rings provide gas-tight seal with no metal seating surface to damage if dropped. Gases are kept separate until entering the mixing chamber.

### Fuel Gas Chart

Generic Name	Trade Name
Acetylene	—
Propane and Propane-Based Mixtures	Propane-butane, Flamex, Acetogen, Chem-O-Lene, Florida Industrial Gas, Hy-Temp, Fuel Gas, I.G. Gas, Chem-Gas, Lingas, Chemtone
Propylene	HPG, Apachi, B-Plus, Gulf HP Gas, HEF, Liquifuel, B.T.U.
Natural Gas (Methane)	Natural Gas, City Gas

**CAUTION: Manifolding cylinders**  
 When required flows (cubic feet per hour – SCFH) exceed the recommended withdrawal rate from one cylinder, then additional cylinders must be manifolded to provide safe and efficient operation. Acetylene must not be withdrawn at more than 1/7 of the cylinder capacity per hour (50 SCFH for a 350 cu. ft. cylinder). Consult your gas supplier for manifolded instructions for the gases and cylinders supplied to you.

# Heavy-Duty Tips

## SW200 Series



The SW200 Series is for general and heavy welding and brazing. Swaged construction provides greater heat concentration for improved "puddle" control. Tips are bent to 63.5-degree angle. O-ring replacement: LW15 (package of 25).

**Compatible torch handles**  
 ■ WH200A, WH200, SW1B, SW1A and SW1

**Fuel gases**  
 These tips may also be used for brazing with acetylene-based fuels and propylene-based fuel gases. When using these gases, select a tip two sizes larger than recommended for the same work as acetylene.

Tip Number	Welding Capacity Inches (mm)	Consumption (SCFH)*		Drill Size
		Oxygen	Acetylene	
SW201	1/32 (0.7)	2.3	2.3	71
SW203	5/64 (1.9)	3.2	3.2	67
SW205	1/8 (3)	6	6	57
SW207	3/16 (5)	12	12	54
SW209	3/8 (10)	23	23	49
SW210	1/2 (13)	36	36	44

\*Consumption (SCFH: cubic feet per hour) figures represent the average volumes of gases consumed when acetylene is added until sooty smoke just disappears from the acetylene flame prior to opening the oxygen valve and adjusting to a neutral flame.

# Medium-Duty Tips

## MW411



General-purpose medium-duty brazing tips designed specifically for use with propane or propane-based mixture fuel gases with oxygen. Used for brazing applications and casting platinum. O-ring replacement: MW15 (package of 25).

**Compatible torch handles**  
 ■ WH100, MW5A and CW5A

Tip Number	Welding Range Inches (mm)	Consumption (SCFH)	
		Oxygen	Fuel
MW411	1/2-5/8 (13-16)	51.9	13

# Medium-Duty Tips

## MW200 Series



The MW200 Series is for general purpose medium-duty welding which features our "soft flame" for easier puddle control and better penetration. Tips are bent to 63.5-degree angle. O-ring replacement: MW15 (package of 25).

**Compatible torch handles**  
 ■ WH100, MW5A and CW5A

**Fuel gases**  
 These tips may also be used for brazing with acetylene-based fuels and propylene-based fuel gases. When using these gases, select a tip two sizes larger than recommended for the same work as acetylene.

Tip Number	Welding Capacity Inches (mm)	Consumption (SCFH)*		Drill Size
		Oxygen	Acetylene	
MW201	1/32 (0.7)	2.3	2.3	71
MW203	5/64 (1.9)	3.2	3.2	67
MW205	1/8 (3)	6	6	57
MW207	3/16 (5)	12	12	54
MW209	3/8 (10)	23	23	49

\*Consumption (SCFH: cubic feet per hour) figures represent the average volumes of gases consumed when acetylene is added until sooty smoke just disappears from the acetylene flame prior to opening the oxygen valve and adjusting to a neutral flame.

# Standard-Duty Tips

## AW200 Airline™ Series



General-purpose standard-duty welding/brazing tips. Shorter, lighter and easier to handle. O-ring replacement: AW15 (package of 25).

**Compatible torch handles**  
 ■ AW1A and AW10A

**Fuel gases**  
 These tips may also be used for brazing with acetylene-based fuels and propylene-based fuel gases. When using these gases, select a tip two sizes larger than recommended for the same work as acetylene.

Tip Number	Welding Capacity Inches (mm)	Consumption (SCFH)*		Drill Size
		Oxygen	Acetylene	
AW201	Up to 1/32 (0.7)	2.3	2.3	71
AW203	5/64 (1.9)	3.2	3.2	67
AW205	1/8 (3)	6	6	57
AW207	3/16 (5)	12	12	54
AW209	3/8 (10)	23	23	49
AW210	1/2 (13)	36	36	44

\*Consumption (SCFH: cubic feet per hour) figures represent the average volumes of gases consumed when acetylene is added until sooty smoke just disappears from the acetylene flame prior to opening the oxygen valve and adjusting to a neutral flame.

## Heating Tips

Heating tips used in torch handles provide significant cost savings in many applications.

Heating tips do jobs faster and cut labor time to a minimum by providing great amounts of quick, concentrated heat. For proper performance, use the recommended pressures for each tip and an adequate gas supply.

- ST** Heavy-duty heating tips
- MT** Medium-duty heating tips
- AT** Standard-duty heating tips

### Fuel Gas Chart

Generic Name	Trade Name
Acetylene	—
Propane and Propane-Based Mixtures	Propane-butane, Flamex, Acetogen, Chem-O-Lene, Florida Industrial Gas, Hy-Temp, Fuel Gas, I.G. Gas, Chem-Gas, Lingas, Chemtone
Propylene	HPG, Apachi, B-Plus, Gulf HP Gas, HEF, Liquifuel, B.T.U.
Natural Gas (Methane)	Natural Gas, City Gas

**CAUTION: Manifolding cylinders**  
When required flows (cubic feet per hour – SCFH) exceed the recommended withdrawal rate from one cylinder, then additional cylinders must be manifolded to provide safe and efficient operation. Acetylene must not be withdrawn at more than 1/7 of the cylinder capacity per hour (50 SCFH for a 350-cu.-ft. cylinder). Consult your gas supplier for manifolding instructions for the gases and cylinders supplied to you.

**CAUTION: Flashback arrestors**  
Heating tips must be used in conjunction with high-flow flashback arrestors. It may be necessary to increase outlet pressures to compensate for flow restrictions that may be created by flashback arrestors.

## Heavy-Duty Tips

### ST600 Series

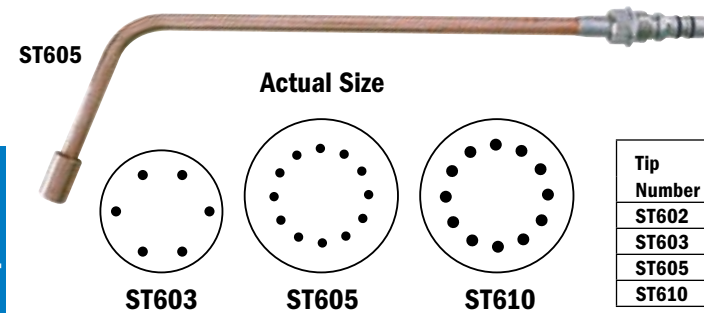

**Acetylene** Multi-flame heating tips for our heavy-duty torch handles. Used for heat treating, bending, straightening, pre-heating, brazing, shrinking, forming, etc. Heads are manufactured from solid copper.

**Compatible torch handles**  
■ WH200A, WH200, SW1B, SW1A and SW1

Tip Number	Average BTU/Hour	Consumption (SCFH)		Drill Size	350 Cu. Ft. Fuel Cylinders Required	Overall Length Inches (mm)
		Oxygen	Acetylene			
ST602	40,125	31	28	64	1	16 (406)
ST603	71,750	55	50	56	1	16 (406)
ST605	124,670	96	87	57	2	19 (483)
ST610	194,890	150	136	54	3	19 (483)

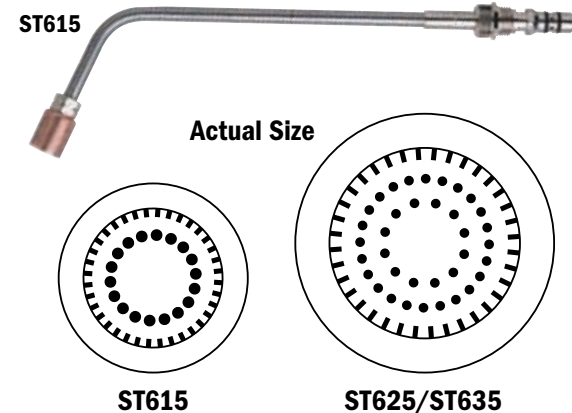

**Propane or Natural Gas**  
**Propylene** Medium pressure oxy-propane or propane-based heating tips provide high heating performance with low-cost fuel gases including natural gas and propane-based gases.

**Compatible torch handles**  
■ WH200A, WH200, SW1B, SW1A and SW1

Tip Number	Average BTU/Hour	Consumption (SCFH)		Overall Length Inches (mm)	Torch Head Number
		Oxygen	Fuel Gas		
ST615	244,000	225-535	70-160 (propane)	16 (406)	1495
	155,145	175-450	96-267 (natural gas)		
	280,000	235-430	100-160		
ST625	455,000	480-1000	140-280 (propane)	31.5 (800)	1504
	313,950	390-785	200-450 (natural gas)		
ST635*	614,195	670-1580	185-480 (propane)	31.5 (800)	1499

\*ST635 requires 3/8-inch (10 mm) I.D. hose and 40-50-510 propane cylinder regulator.

## Heavy-Duty Tips

### ST800 Series

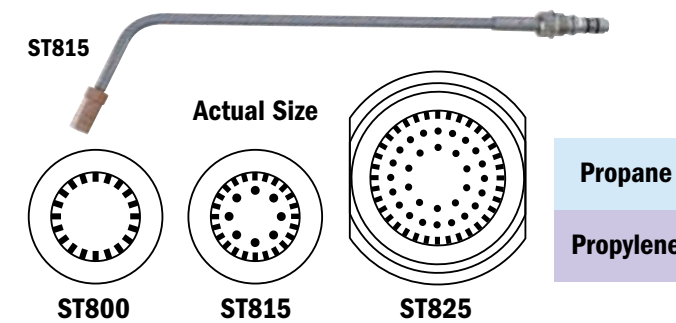

Medium pressure oxy-propane or propane-based heating tips provide high heating performance with low-cost fuel gases including natural gas and propane-based gases.

**Compatible torch handles**  
■ WH200A, WH200, SW1B, SW1A and SW1

Tip Number	Average BTU/Hour	Consumption (SCFH)		Overall Length Inches (mm)	Torch Head Number
		Oxygen	Fuel Gas		
ST800	58,000	107-108	22-24	15.5 (394)	16317
	75,000	118-138	31-34		
ST815	273,000	390-655	120-235	16 (406)	4642
ST825	830,000	580-1500	225-525	31 (787)	4639

Note: Use 3/8-inch (10 mm) I.D. hose.

## Medium-Duty Tips

### MT800 Series and MT615

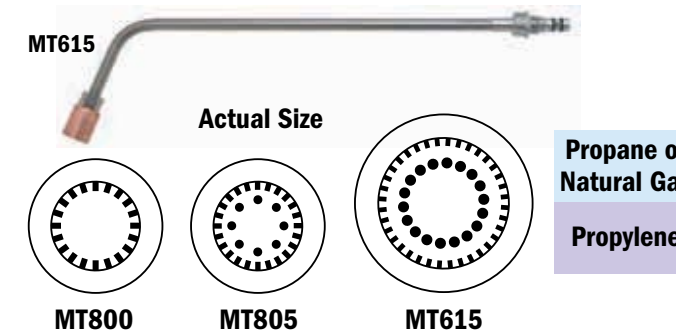

Medium pressure oxy-propane or propane-based heating tips provide high heating performance with low-cost fuel gases including natural gas and propane-based gases.

**Compatible torch handles**  
■ WH100, MW5A and CW5A

Tip Number	Average BTU/Hour	Consumption (SCFH)		Overall Length Inches (mm)	Torch Head Number
		Oxygen	Fuel Gas		
MT800	93,000	119-121	36-38 (propane)	12.5 (318)	16317
	123,000	135-146	51-56		
MT805	208,000	206-230	80-100 (propane)	15 (381)	4642
	280,000	242-270	120-135		
MT615	269,000	225-535	70-160 (propane)	15 (381)	1495
	182,000	175-450	96-267 (natural gas)		
	280,000	235-430	100-160		

## Medium-Duty Tips

### MT600 Series

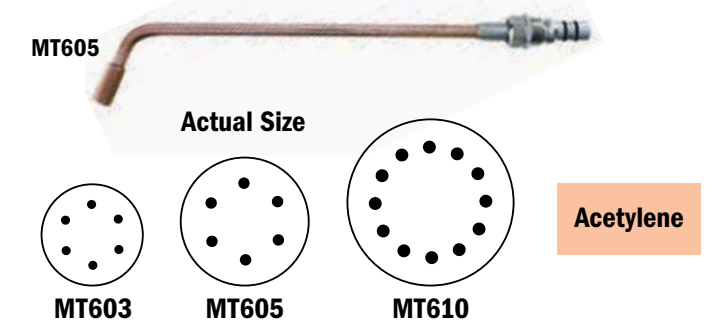

Versatile multi-flame heating tips for the popular medium-duty torch handles. Used for general heating of metals, brazing, hard surfacing, etc. Heads are manufactured from solid copper.

**Compatible torch handles**  
■ WH100, MW5A and CW5A

Tip Number	Average BTU/Hour	Consumption (SCFH)		Drill Size	350 Cu. Ft. Fuel Cylinders Required	Overall Length Inches (mm)
		Oxygen	Acetylene			
MT603	40,125	31	28	64	1	10 (254)
MT605	73,085	57	51	56	1	16 (406)
MT610	128,970	100	90	57	2	18 (457)

## Standard-Duty Tips

### AT605



Handy light-duty multi-flame tip for heating, brazing and applying hard facing metals. Uses medium pressure acetylene and oxygen. Heads are manufactured from solid copper.

**Compatible torch handles**  
■ AW1A and AW10A

Tip Number	Average BTU/Hour	Consumption (SCFH)		Drill Size	200 Cu. Ft. Fuel Cylinders Required	Overall Length Inches (mm)
		Oxygen	Acetylene			
AT605	41,550	32	29	64	1	10 (254)

Note: Tips may also be used with oxygen/hydrogen.

# Heavy-Duty Special-Purpose Heating Tips

## Compressed Air Heating Tip



**NE170**  
Length: 15-5/8 inches (397 mm)  
Weight: 2.3 lb. (1 kg)

### Propane or Natural Gas

Produces concentrated flame not normally possible with low-cost natural gas. Ideal for a wide range of heating applications including die casting. Produces temperatures of 3400 degrees Fahrenheit with natural gas and 3500 degrees Fahrenheit with propane. Operates on gas pressures of 2-10 PSIG and 10-100 PSIG compressed air. For maximum heat output, a minimum of 30 PSIG air is required.

#### Compatible torch handles

- WH200A, WH200, SW1B, SW1A and SW1

Tip Number	Consists of		
	Gas Mixer	Tip Head	Gooseneck
NE170	ST625B	NE171 86,000 BTU/hour	NE171-1

Note: Hex tip tube adaptor is part number 15855.

## Railroad Heating Tip (Preheat for Thermite Rail Welding)

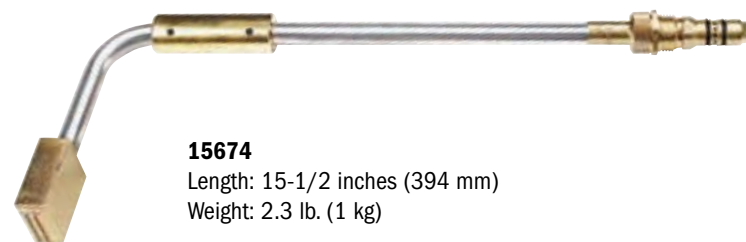

**15674**  
Length: 15-1/2 inches (394 mm)  
Weight: 2.3 lb. (1 kg)

### Propane

Five-minute-style preheating tip for rail welding. May also be used for additional heating applications.

#### Compatible torch handles

- WH200A, WH200, SW1B, SW1A and SW1

Tip Number	Average BTU/Hour	Consumption (SCFH)	
		Oxygen	Propane
15674	150,000	275	70

#### CAUTION: Liquid oxygen

When using liquid oxygen, tips may require greater gas volume than a single cylinder is capable of producing. External evaporators or manifolding multiple cylinders may be necessary to supply sufficient gas flows.

#### CAUTION: Flashback arrestors

Heating tips must be used in conjunction with high-flow flashback arrestors. It may be necessary to increase outlet pressures to compensate for flow restrictions that may be created by flashback arrestors.

#### CAUTION: Manifolded cylinders

When required flows (cubic feet per hour – SCFH) exceed the recommended withdrawal rate from one cylinder, then additional cylinders must be manifolded to provide safe and efficient operation.

# Accessories

## Welding Protection



Men's INDURA cloth jacket

Women's INDURA cloth jacket

Combo sleeves

MIG gloves (lined)

Multitask gloves

Safety glasses

### INDURA® Cloth Jacket

#### Men's

- #258 095 Small    #258 099 X-Large    #258 102 4X-Large
- #258 097 Medium    #258 100 2X-Large    #258 104 5X-Large
- #258 098 Large    #258 101 3X-Large

#### Women's

- #264 379 Small    #264 381 Large    #264 383 2X-Large
- #264 380 Medium    #264 382 X-Large

- INDURA flame-resistant cotton (flame resistance guaranteed for life of jacket) and Nomex® flame-resistant thread
- Allows for patented bib/apron attachment

### Combo Sleeves #231 096

- INDURA flame-resistant cotton/top grain leather
- 21-inch (533 mm) length

### MIG Gloves (Lined)

- #263 330 X-Small (Women's)    #263 333 Large
- #263 331 Small (Women's)    #263 334 X-Large
- #263 332 Medium

- Dual-padded, fleece-insulated palm with foam-insulated back
- Cow grain palm, pig split back and goat grain inner fingers

### Multitask Gloves

- #263 352 Small    #263 354 Large
- #263 353 Medium    #263 355 X-Large

- Dual-padded palm with wool-insulated back
- Premium goat grain leather

### Safety Glasses (shade 5)

- #235 658 Black    #235 657 Blue    #235 659 Orange
- Form fitting orbital eye coverage
- ANSI Z87.1 compliant

## GASAVER™



Note: NOT for use with one-piece cutting torch. Contact factory for pilot options available for alternate fuels.

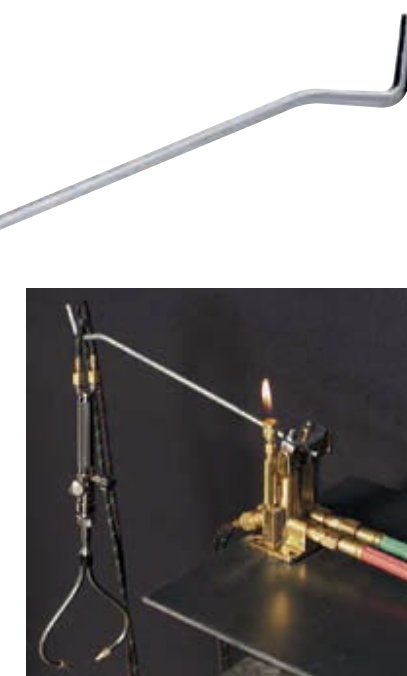

### Save money, save time and improve safety.

Ideal for production brazing and welding applications, our GASAVER can help you realize huge savings by eliminating wasted gas during torch start-up/shut-down and between flame applications. Save time by eliminating repeated torch adjustment. GASAVER gives you a safe place to temporarily put your torch and is used by America's largest production plants. Torch flame is automatically extinguished when torch is not in use. Simply pass torch over pilot flame to re-light.

**WDW100** is standard GASAVER for use with propylene gas and oxygen. Equipped with adjustable pilot light.

**WDW101** is GASAVER for general use with acetylene and oxygen. Can be installed in any convenient location on the line between regulators and torch. The closer the torch, the greater the savings in oxygen and acetylene. Equipped with adjustable pilot light.

**WDW103** is GASAVER equipped with separate adjustable pilot fuel inlet for use with low-pressure gas with injector type torches. Separate source of high-pressure pilot gas required. May also be used with hydrogen gas, however propane or natural gas is recommended to supply the adjustable pilot light.

**WDW104** is standard GASAVER equipped with adjustable pilot light for use with propane or natural gas at 4 PSI or more.

## Hoses and Hose Fittings



**IMPORTANT:** "R"-Grade welding hose is for use with acetylene only, as specified by the RMA-CGA Hose Standard. "T"-Grade hose must be used with all other gases.

**CAUTION:** Do not exceed the maximum working pressures (regulator setting) listed for the hoses during welding and cutting operations.

**Oxygen** (150 PSIG max.)  
**Acetylene** (15 PSIG max.)  
**Propane, propylene and all other fuel gases** (40 PSIG max.)



### Hose Adaptors and Connections

Product	Stock Number	Type	Thread
Hose Adaptors ("B" regulators to "A" hose fitting)	14389	Oxygen	3/8"-24 RH (male thread)
	14390	Fuel Gas	9/16"-18 RH (female thread)
Torch Hose Connections (Nickel plated for use with all heavy-duty torch handles and hand torches)	3060-1	Oxygen	9/16"-18 RH
	3060-2	Fuel Gas	9/16"-18 LH

**Sintered Filter (10 pack) 15775-10**  
 Sintered filter to prevent debris from entering torch. Installs inside "B" torch inlet connections. Not for use with Gas Axe torches.

## Oxy Accessories



Stock Number	Product
N230	Cylinder Wrench
N250	Tip Cleaner (sharp point spiral)
N113ANB	Flint Lighter (N113-3 replacement flints) (5 per pkg.)
13493	Caddy Carrier with hose wrap and storage compartment for MC acetylene and 20 cu. ft. oxygen cylinders.
NE135B	Two-Hose Manifold – oxygen "B" connections
NE136B	Two-Hose Manifold – fuel "B" connections
16229	Circle Cutting Guide cuts from 5/8" to 12" diameter holes. Works with all SC and MC style cutting tips.



### Twin Hoses (Two-In-One)

Hose Type	Stock Number	Length	ID Diameter	Connections	
				To Regulators	To Torches
"R"-Grade (for Acetylene only)	RL1131	25 ft. (7.6 m)	1/4 in. (6 mm)	R11 (Oxygen) R12 (Fuel) 9/16"-18 ("B")	R11 (Oxygen) R12 (Fuel) 9/16"-18 ("B")
	RL921	12.5 ft. (3.8 m)	3/16 in. (5 mm)	R13D (Oxygen) R14D (Fuel) 9/16"-18 ("B")	R13D (Oxygen) R14D (Fuel) 9/16"-18 ("B")
	RL935	20 ft. (6.1 m)	3/16 in. (5 mm)	R13D (Oxygen) R14D (Fuel) 9/16"-18 ("B")	R13 (Oxygen) R14 (Fuel) 3/8"-24 ("A")
	RA921	12.5 ft. (3.8 m)	3/16 in. (5 mm)	R13D (Oxygen) R14D (Fuel) 9/16"-18 ("B")	R13 (Oxygen) R14 (Fuel) 3/8"-24 ("A")
"T"-Grade (for LP, Propane, Propylene, Acetylene)	TRL1131	20 ft. (6.1 m)	1/4 in. (6 mm)	R11 (Oxygen) R12 (Fuel) 9/16"-18 ("B")	R11 (Oxygen) R12 (Fuel) 9/16"-18 ("B")
Kevlar® Brazing Hose (for AW1A handle only)	14779-4-10	10 ft. (3 m)	1/8 in. (3 mm)	R13D (Oxygen) R14D (Fuel) 9/16"-18 ("B")	R13 (Oxygen) R14 (Fuel) 3/8"-24 ("A")

### Single Hoses

Hose Type	Stock Number	Length	ID Diameter	Connections	For Use With
"R"-Grade (for Acetylene only)	RL121	12.5 ft. (3.8 m)	3/16 in. (5 mm)	9/16"-18 LH ("B")	NE180 Handi-Heat torch
Black Hose (for Inert gas)	7294-1	6 ft. (1.8 m)	1/4 in. (6 mm)	5/8"-18 RH Male	Flow gauges and flowmeter regulators
Heavy-Duty Charging Hose (for use with Nitrogen for HVAC purging apps)	RL260	6 ft. (1.8 m)	1/4 in. (6 mm)	7/16"-20 RH Internal to regulator, 7/16"-20 RH with core to A/C unit	30-450-580 regulators (depress to open Schraeder valve)

## Safety Accessories

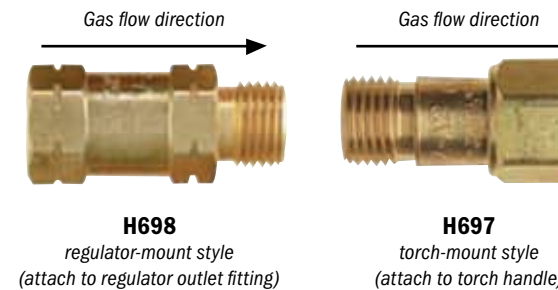

**We cannot accept return of check valves or flashback arrestors as these products are subject to controls that may be compromised after shipping.**



**CAUTION:** Flashback arrestors will contribute to significant pressure drop in a system, causing reduced flow. Pressure increase may be required to maintain equivalent flow rates after installing flashback arrestors in an oxy-fuel system.

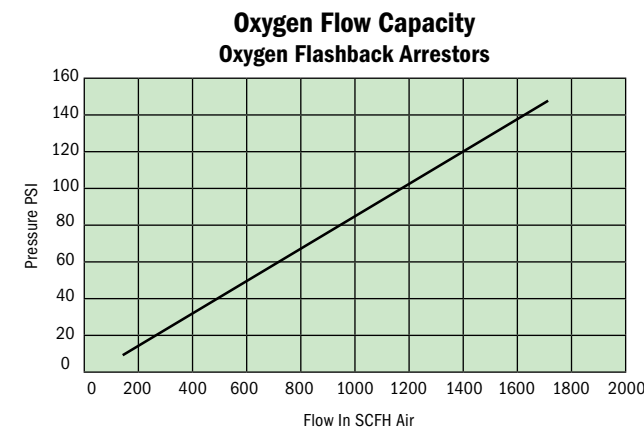

### Hard Hat™ Regulator Guards

Protect regulators from costly gauge replacement with our Hard Hat gauge guards. Promotes safety... designed to help prevent broken gauges which can lead to gas leaks. Time and cost savings... helps prevent costly equipment down time and expensive repairs.

**HB190 Hard Hat** is made from rugged steel with a bright yellow, baked-enamel finish. Quickly and easily attaches to regulator. Fits Series 40™, HB1500 and HB2100 Series brass regulators.

**H195 Hard Hat** is formed from extremely tough, impact-resistant polycarbonate resin with a bright, safety-yellow finish. Fits Series 30™ and 1700 Series single-stage regulators.

*Note: Will not work with flow gauge regulators.*

### Reverse-Flow Check Valves

Reverse-flow check valves are an important part of any oxy-fuel system. Without check valves, reverse flow of oxygen and fuel gases can occur when a tip becomes clogged, or when one cylinder empties during use. This could allow the higher pressure gas to back up into the other hose and into the regulator, thereby creating conditions which could lead to a regulator explosion. Our reverse-flow check valves close automatically when outlet pressures drop below 1/2 PSIG, preventing reverse flow of gases.

Check Valve Type	Stock Number	Gas	Inlet Connection	Outlet Connection
Regulator Mount	H698	Pair	9/16"-18 LH and RH Internal	9/16"-18 LH and RH External
Torch Mount	H697	Pair	9/16"-18 LH and RH External	9/16"-18 LH and RH Internal

*Note: Check valves should be replaced on a regular basis.*

### Flashback Arrestors

- May be used with acetylene, propane, propylene, hydrogen and natural gas
- Built-in check valve prevents the reverse flow of gas
- Requires no manual reset
- Easy to install – attaches to standard "B" fittings
- High-quality brass construction, case is rugged and corrosion-resistant
- Sintered stainless steel filter stops flashback fire

Flashback Arrestor Type	Stock Number	Gas
Regulator Mount (for use with CGA "B" male fitting)	H753	Oxygen and fuel gas pair
Torch Mount (High Flow) (do NOT exceed 15 PSIG when using acetylene gas)	H743	Oxygen and fuel gas pair

*Note: Flashback arrestors should be tested and inspected on a regular basis.*

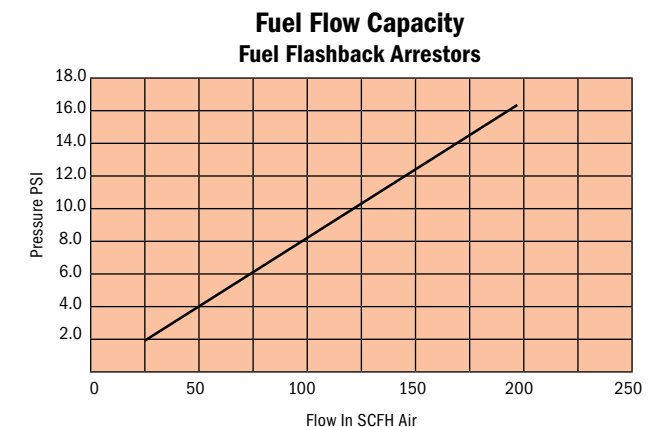

# Blue and you.

## CONTENTS

### Outfits

- 3 Outfits Intro
- 4 Heavy-Duty Cutting, Welding & Heating
- 5 Heavy-Duty Cutting
- 6 Medium-Duty Cutting, Welding & Heating
- 7 Toughcut™ Cutting, Welding & Heating
- 8 Tag-A-Long™ and Versa-Torch™
- 9 Combination Torch and Tip Packages

### Torches

- 10 Torch Handles
- 12 Cutting Attachments
- 14 Hand Cutting Torches
- 16 Gas Axe™ Hand Cutting Torches
- 17 Machine Cutting Torches

### Regulators

- 18 Single-Stage Regulators
- 20 Specialty Regulators
- 22 Flowmeter Regulators
- 24 Flowmeters
- 24 Flow Gauge Regulators
- 25 Fixed-Flow Adaptors and Surge Protectors
- 25 Premium-Quality Gauges
- 26 Proportional Standard Two-Gas Mixer

### Tips

- 27 Cutting and Special-Purpose
- 32 Welding
- 34 Heating

### Accessories

- 37 Welding Protection
- 37 GASAVER™
- 38 Hoses and Hose Fittings
- 38 Oxy and Safety Accessories

## Refine your skills and connect with other welders at MillerWelds.com

The **Miller® Video Library** contains how-to videos covering nearly every welding project and technique imaginable. Click on the “Resources” tab, or visit the Miller Welding channel on **YouTube**.



Are you a do-it-yourselfer? Professional welder? Welding instructor? Sign up for your choice of newsletters and get informative articles delivered right to your email inbox. Just visit **MillerWelds.com/newsletters** to get started.



Click on “Welding Projects” under the “Industries & Interests” tab to see the **Miller® WE BUILD Project Gallery:**



hundreds of project photos from welders of all skill levels.

**Product information** is always available at MillerWelds.com. Get complete access to detailed product specs, accessories and pricing.

