

Manipulator



Since 1966

►► Scaled-Down type

ProArc delivers compact design manipulator suitable for TIG & MIG circumferential welding application. It can be combined with welding positioner or turning rolls as a cost saving welding package to make your welding easy and quick.

Features

- Rigid steel structure.
- Employ linear guideway and ballscrew yielding precise welding and better quality.
- Transverse adjustment by manually and equipped with quick lock handle.
- Boom lifting can be adjusted by manual or electrical control.
- Equips with 360 deg. rotation base for flexible welding application.
- Quick torch position adjustment in X/Y/Z axis through manual slide.
- Compact design to save floor space and easy for installation.
- Can be combined with welding positioner or turning rolls as welding package.



■ MP-0606 with PT-750

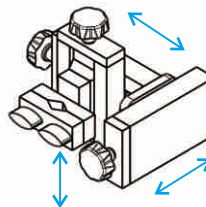

■ Torch adjustment slide

Specifications

Model	Unit	MP-0606E	MP-1212E	MP-0606	MP-1212
Power input		1ph, 100~240V, 50 / 60Hz			
Stroke (F x G)	mm	600 x 600	1200 x 1200	600 x 600	1200 x 1200
Transverse		Linear guideway			
Lifting		Ball screw with linear guideway			
Transverse adjustment		Manual			
Lifting adjustment		1/12 HP PMDC motor			
Lift speed	mm/min	950			
Column rotation	deg	360 (manual)			
Overall height (A)	mm	1470	2070	1470	2070
Overall width (B)	mm	1110	1700	1110	1700
Overall length (C)	mm	250			
Min. height torch to floor (D)	mm	600			
Min. distance torch to center (E)	mm	300			
Boom load capacity	kg	20			

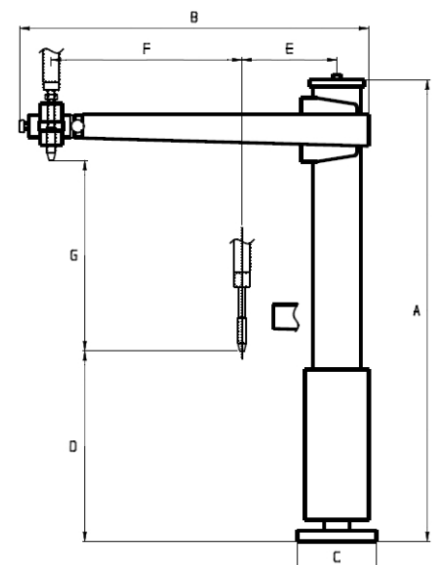

*Specifications subject to change without notice