

Self-Aligning Turning Rolls

Self-aligning turning rolls adjust roller centerline setting automatically when loading your workpiece into the rolls. Pairs of two support rollers are suspended to be self-aligning. The self-alignment rolls which maintain a contact centerline can rotate work pieces from Ø300mm to 6,000mm and weights ranging from 12~60 tons.

Turning rolls is used to accurately rotate a part to produce high quality welds in a variety of different applications.



Wheel & Brake set

All ProArc turning rolls can be equipped with wheel & brake set easily. Mount on the track, the turning rolls can be transported to work stations conveniently. Equipped with optional wheels, it enhances the efficiency of production flow.

ProArc welding products

- Quality
- Friendly design
- Long service life
- High CP value

- Automatic adjustment for different workpiece diameters
- Ideal for difficult and demanding workpieces
- Even weight distribution



47 years of welding automation excellence

Specification					
Model	Unit	TR-12KA	TR-24KA	TR-40KA	TR-60KA
Power input		AC 220 / 380V 50 / 60Hz, 3 phase		AC 220 / 380V 50 / 60Hz, 3 phase	
Drive motor	hp	1/2 + 1/2	1/2 + 1/2	1 + 1	2 + 2
Overall length (A)(drive / idler)	mm	1,930 / 1,630	2,160 / 1,860	2,460 / 2,160	2,460 / 2,160
Overall width (B)	mm	865	935	1,040	1,115
Overall height (C)	mm	972			
Load capacity (drive)	kg	6K	12K	20K	30K
Load capacity (idler)	kg	6K	12K	20K	30K
Turning capacity	kg	12K	24K	40K	60K
Diameter range (D)	mm	Ø300 ~ 4,000	Ø600 ~ 5,000	Ø1,000 ~ 6,000	Ø1,000 ~ 6,000
Speed range	mm/min	100 ~ 1,500			
Wheel diameter (E)	mm	300			
Wheel width (F)	mm	100	170	275	350
Wheel type		PU			

Specifications subject to change without notice

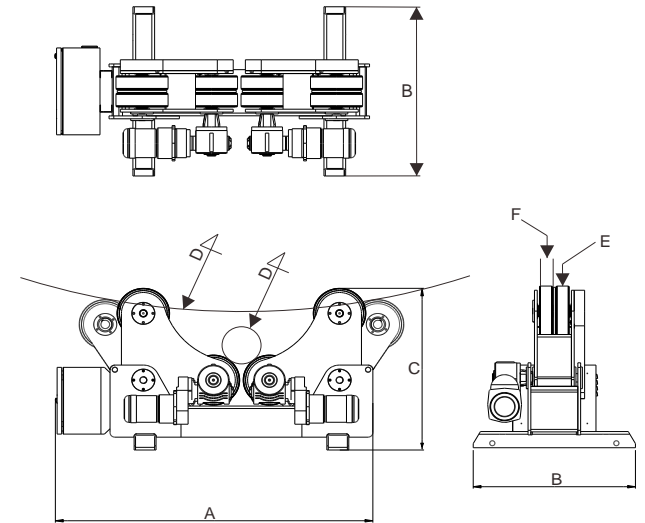

Optional accessories

- Wheel & brake set
- Track
- Electric travel car
- Digital tachometer

